

HOW A TELEVISION RECEIVER PRODUCES ITS PICTURES

# Television

and *SHORT-WAVE WORLD*

SEPTEMBER, 1937

No. 115. Vol. x.

1/-  
MONTHLY



## TELEVISION *at* RADIOLYMPIA

**Radiolympia:**  
ITS PICTURES  
AND RECEIVERS

IMPROVED  
TELEVISION  
SERVICE

GERMAN PROGRESS

TELEVISION  
SIGNALS ACROSS  
THE ATLANTIC

MINIATURE  
TELEVISION

SHORT  
WAVES

T20  
TRANSMITTER

OLYMPIA  
REVIEW

BEAM VALVE  
OSCILLATOR

BERNARD JONES PUBLICATIONS LTD.  
CHANSITOR HOUSE, CHANCERY LANE  
LONDON W.C.2.

THE FIRST TELEVISION JOURNAL IN THE WORLD

# TELEVISION DEVELOPMENTS

## A NEW LARGE DIAMETER TUBE FOR TELEVISION REPRODUCTION

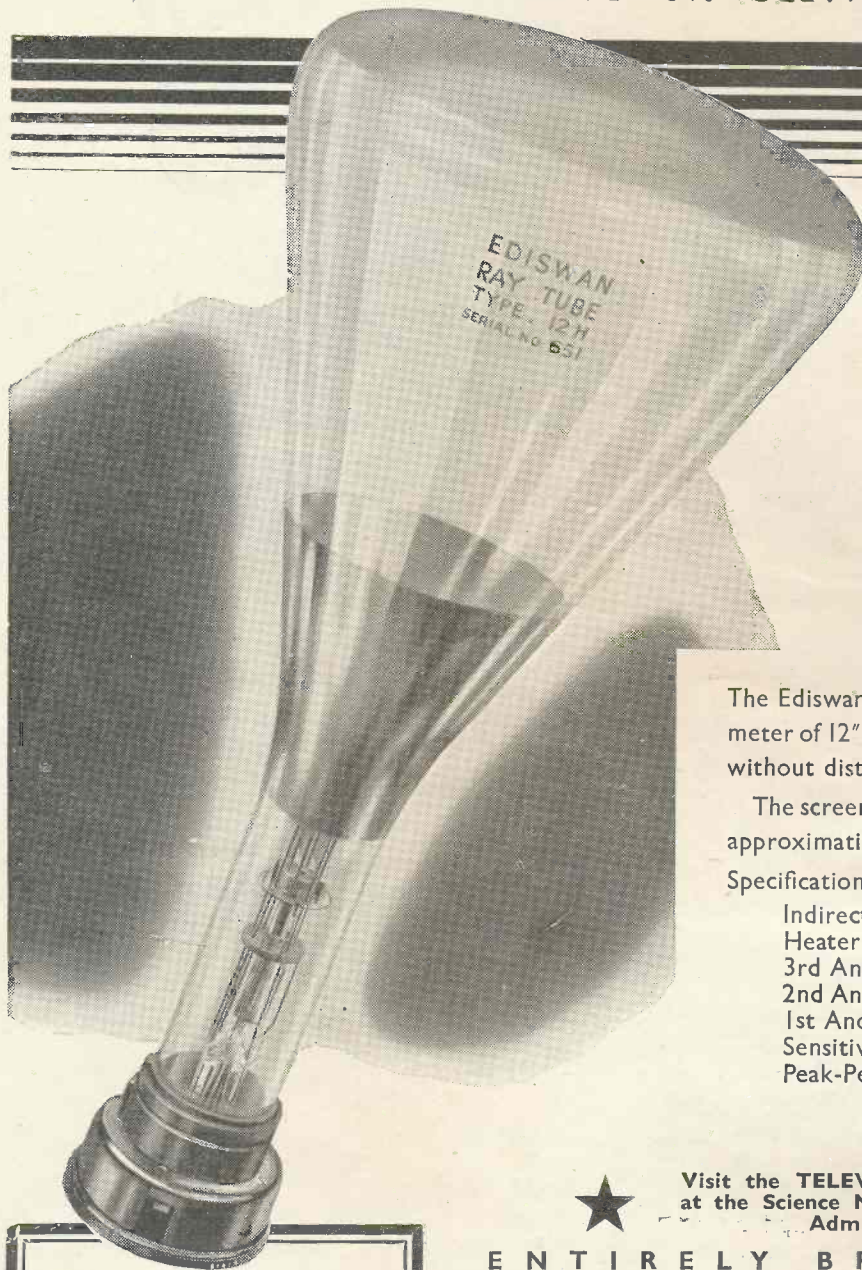

**TYPE 12H  
TUBE**

The Ediswan Type 12H tube has a screen diameter of 12" giving a television picture 10" x 7½" without distortion.

The screen is of special material giving a close approximation to a black-and-white picture.

Specification:

Indirectly heated high vacuum tube.	
Heater Volts - - -	2.0
3rd Anode Volts - - -	6000
2nd Anode Volts - - -	1200
1st Anode Volts - - -	300
Sensitivity (mm./V.) - -	850/V*
Peak-Peak Modulating Volts -	15

\*V=3rd anode volts

List Price £15 . 15 . 0



Visit the TELEVISION EXHIBITION  
at the Science Museum, S. Kensington.  
Admission Free.

ENTIRELY BRITISH MADE

# EDISWAN RADIO VALVES

● We also supply  
HIGH VACUUM RECTIFIERS  
GAS-FILLED RELAYS  
MERCURY VAPOUR RELAYS  
for Television Scanning  
circuits.

THE EDISON SWAN ELECTRIC CO. LTD.



155 CHARING CROSS RD., LONDON, W.C.2

R.E.299

### USED BY ALL GOVERNMENT DEPARTMENTS

# TELEVISION

## and SHORT-WAVE WORLD

### Special Features

We Show you How a Television Receiver Produces the Picture ... 517

Experimental Miniature Television ... 523

Television Signals Across the Atlantic 527

Radiolympia: Its Pictures and Receivers ... 532

Television and the Kinema ... 539

German Television Progress ... 541

Recent Developments ... 543

T20 Transmitter ... 547

Radiolympia Exhibits of Short-Wave Interest ... 552

Beam Valve Oscillator ... 558

Vibrator Battery Eliminator ... 562

Typical Power Supply Circuits ... 566

#### TELEVISION AND SHORT-WAVE WORLD

Proprietors :  
BERNARD JONES PUBLICATIONS, LTD.

Editor-in-Chief :  
BERNARD E. JONES.

Editor :  
H. CORBISHLEY.  
Editorial, Advertising and Publishing Offices :

Chansitor House, 38, Chancery Lane, London, W.C.2.

Telephones : Holborn 6158, 6159  
Telegrams : Beejapee, Holb., London.

Subscription Rates : Post paid to any part of the world—3 months, 3/6; 6 months, 6/9; 12 months 13/6.

Published Monthly—1/- net.  
(Last Wednesday in every month for following month).

Contributions are invited and will be promptly considered. Correspondence should be addressed according to its nature, to the Editor, the Advertisement Manager, or the Publisher, "Television and Short-wave World," Chansitor House, Chancery Lane, London, W.C.2.

#### IMPORTANT

"Television and Short-wave World" is registered at the General Post Office, London, for transmission to Canada and Newfoundland by Magazine Post. Entered as Second-class mail matter, Boston, Mass.

## COMMENT OF THE MONTH

### British Television Still Leads

THE accounts that have been published in a large section of the Press regarding German television progress as revealed at the Berlin exhibition are apt to convey the idea that in their development work the Germans have pulled ahead of this country. The reason for this is that development appears to be on a bigger scale; for example, a standard of 441 lines has been adopted which to the lay mind might appear to be better than our 405. Then we read of large-size projected pictures which again might convey the idea that they are better than anything that has been done in this country.

We have no wish to belittle the German efforts, but it would seem that their objective has been to create an impression. It should be remembered that the German demonstrations were entirely of a laboratory character, without any practical commercial basis. Transmission was entirely by land line with its consequent simplification. Although, admittedly, a 441-line picture can be superior to one of 405 lines, this superiority was not apparent and, under radio transmission conditions, could easily be inferior. It should also be remembered that large-screen high-definition pictures have been produced in this country by mechanical-optical methods which are the equal of the German efforts. On the whole we do not appear to have much to learn from Germany in spite of lavish outlay on research and State grants.

### Popularising Television

ONE of the leading authorities on television in this country recently gave it as his opinion that the way to popularise television was to make it possible for the amateur constructor to build his own receiver. "Get the amateur interested," he said, "and sales of commercial receivers will inevitably follow." We thoroughly endorse this opinion, but until recently there have been the two obstacles of cost and complication which have made the amateur somewhat chary of home construction. We are glad to be able to say, however, that these obstacles have been, in a very great measure, removed and on another page (522) we make a special announcement that will be of interest to all home-constructors.

VISIT TELEVISION'S STAND AT OLYMPIA No. 105



# "HIS MASTER'S VOICE" TELEVISION

is designed  
and made by the engineers  
responsible for the Television  
Transmission System adopted by  
the B.B.C. at Alexandra Palace

● VISIT STAND NO. 76 AND TELEVISION THEATRE NO. 14 RADIOLYMPIA

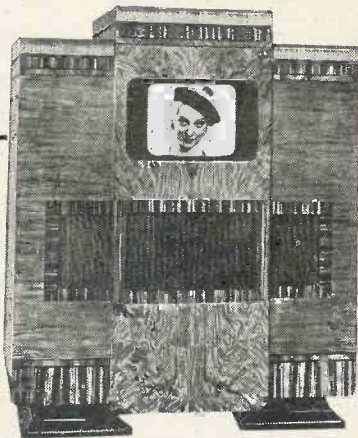

**MODEL 902.** The newest development in home entertainment. "H.M.V." Television Receiver, All-World Radio and Electrical Gramophone - **120 GNS.**

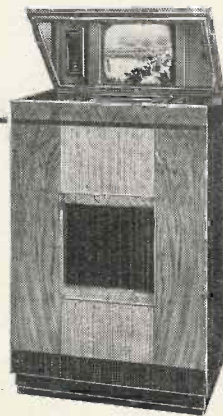

**MODEL 901.** "His Master's Voice" Television Sight and Sound Receiver. **Cash Price 60 GNS.**

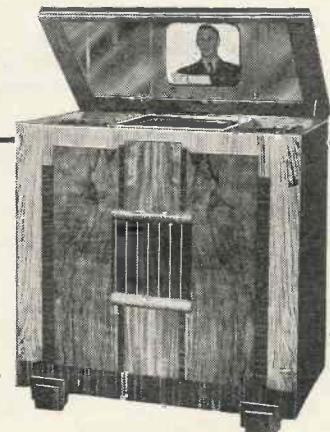

**MODEL 900.** A "His Master's Voice" Television Receiver and All-World Radio. Receives short wave programmes from U.S.A., etc. **Cash Price 80 GNS.**

# WE SHOW YOU HOW A TELEVISION RECEIVER PRODUCES THE PICTURE

You have seen the television pictures, perhaps for the first time; you have probably made a comparison with the cinema and however critical you may be, you will admit that except in the matter of size they bear comparison very well. You may think that television is beyond your ability to understand. Television is one of the most wonderful accomplishments of modern science but its comprehension is easily within your ability and the purpose of this article is to enable you to understand how the picture is produced.

THESE are three main functions in a television system—the “taking” of the picture in the studio, its transmission over a distance, and its reproduction at any place within the range of the transmitter. Also there are two fundamental facts upon which the whole possibility of television depends. These are: that with our present knowledge it is not practicable to transmit the picture as a whole, and that television, as in the case of the cinema, depends upon the well-known “persistence of vision” effect.

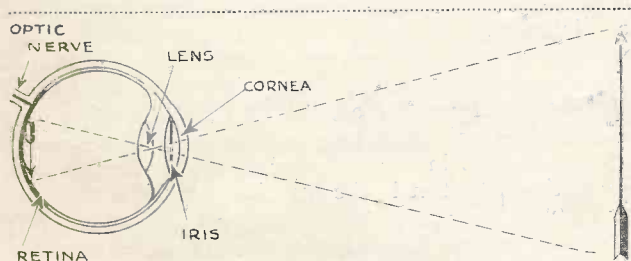

There are many thousands of connecting channels between the retina of the eye and the brain. This diagram shows how the image is focused on the retina from which the light impulses are transferred to the brain simultaneously via the optic nerve.

In sound broadcasting an ensemble of all the complex sounds of an orchestra or speech can be transmitted at once. The same thing applies to recorded sound; all the complex sounds of an orchestra can be recorded as a wavy line on a disc and be reproduced by a single simple diaphragm, there being no need to deal with each individual instrument separately. It is also important to remember that in the case of sound transmission, be it by line or radio, only one communication channel is required. We can appreciate this point still further by considering the characteristic features of the eye and the ear. The ear, compared with the eye is a comparatively simple organ, relying for its functioning upon a simple diaphragm.

## We Cannot Imitate Nature

Now as for sound reproduction we simulate nature's methods, how is it that we cannot do the same in the case of vision. We know that vision is transmitted from the eye to the brain and it will be helpful to discuss how this comes about and consider whether the process could be imitated in any way for the purpose of vision transmission between distant points.

The eye consists very briefly of a crystalline lens, which produces an image of the object being looked at

on the retina. It is at the retina that the light vibrations are changed to what we term sight and it is the physical structure of the retina which is the limiting factor as to the smallness of what the eye can see.

The retina is a transparent membrane, lining the interior of the eye. It consists of two layers of tissue. Nerves from the main optic nerve finally terminate on small elongated bodies called rods and cones which are tightly packed together, not unlike the hairs of a brush. It is on the tips of these cones and rods that the image of a scene falls and for two small neighbouring objects to be distinguished the images must fall on separate cones, which are from .002 to .006 millimetre diameter.

The eye sees by breaking up the image formed inside



Close examination of this picture will show that it is composed of thousands of dots of varying degrees of light and shade and obviously it would be possible to separate the units of which it is composed and re-assemble them.

into definite areas and of different intensities according to the amount of light reflected from the original scene. Thus any scene, as far as vision is concerned, is composed of a large number of positioned elements of various intensities of light, all of which are operating on the brain *simultaneously*

Now the important point that emerges from this is

## AN OUTLINE OF TELEVISION PRINCIPLES

that there are thousands of communication channels from the eye to the brain in order that any image that is focused on the retina may as a whole affect the brain. It was stated previously that to simulate this feature of vision is impracticable in the light of our present knowledge. It would not be impossible, but for any-

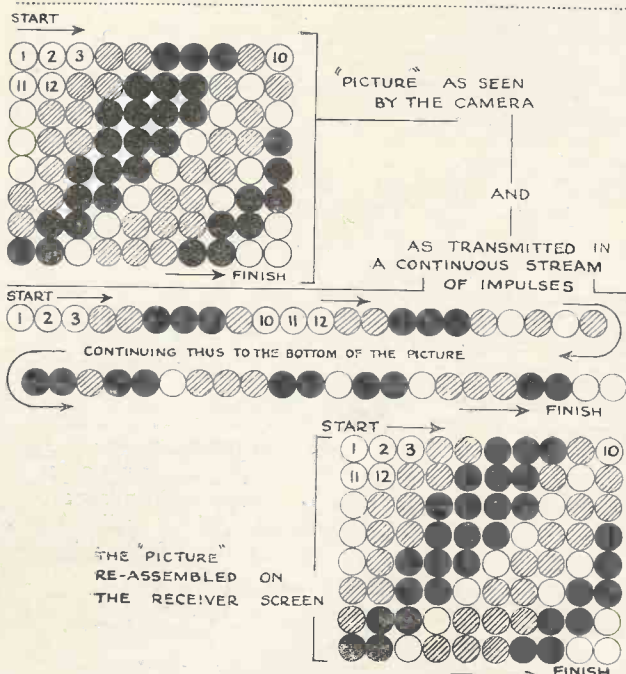

Here is an imaginary analysis of a picture with the units greatly enlarged. The diagram shows how the image can be broken up and transmitted in proper sequence and finally re-assembled to form the original.

thing like reasonable definition some 120,000 wires (if the transmission were to be by line) or radio channels for radio transmission would be required and this is, of course, quite out of the question.

As we cannot employ a huge number of communication channels, what is the alternative? If you look closely at the photograph reproduced on page 517 it will be seen that it is composed of a large number of dots of various intensities. Hold the picture some distance away and the dots of which it is composed are no longer visible. Obviously the degree of definition depends upon the size of the dots, and the number contained in the picture will depend upon their size.

This unit picture composition gives us the key to the solution of practicable television. Suppose that you were to start at the top left-hand corner of the picture and cut off each dot from left to right and line by line and stick them in the same order on another sheet of paper, you would have as a result a composite picture which would correspond almost exactly with the original. Obviously where there was the same tone value in the horizontal direction there would be no necessity to divide that particular section into a series of dots.

### Taking the Picture to Pieces

Here then we have a principle by which a picture

can be analysed at some place and reconstructed at another and it is the principle that is employed in television transmission. The B.B.C. at the Alexandra Palace takes the picture unit by unit, converts its light values into corresponding values of electricity and broadcasts them. As we are only concerned with the receiver it will not be necessary to consider in detail how this is done. It will suffice to say that the B.B.C. transmitter at Alexandra Palace sends out a rapid series of impulses representative of the light and shade values of the original picture or scene, and that they are sent out in a regular sequence.

In the receiver we have to convert these electrical impulses into light of corresponding values and then place these light units on the receiver screen in the same order as they were on the original at the time of transmission. Reverting to our experiment with the cut-up picture, obviously it would be useless were the units of which the picture was composed assembled in any haphazard fashion—the whole thing would be a meaningless mass of light and shade.

At this point it is necessary to consider what part the persistence of vision effect plays. The transmitted impulses are of exceedingly short duration, actually their duration depends upon the number of units into which the picture is analysed and the number of pictures that are transmitted per second. Persistence of vision lasts approximately for one-tenth of a second and an idea of motion can be obtained therefore by projecting ten pictures per second. This low rate, however, results in a great deal of flicker and in the case of the cinema it is the practice to project twenty-four pictures per second and black each one out so that actually there are forty-eight projections per second.

For the sake of this explanation we will assume a picture speed of twenty-five per second (actually this speed results in a considerable amount of flicker, which

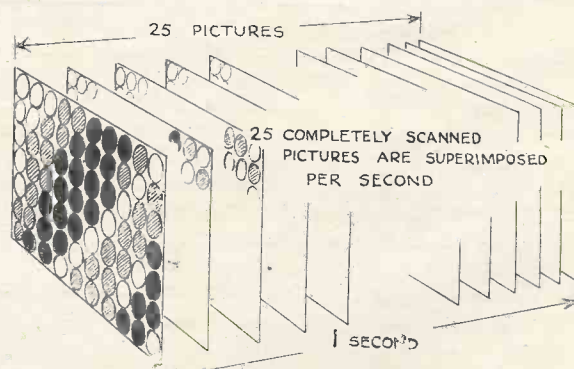

This diagram conveys the idea of how successive pictures can be thrown upon the screen and owing to the persistence of vision effect give an idea of continuity of motion.

has been obviated by a method of interlacing which does not affect this explanation). Obviously then, the splitting up of the picture at the transmitter and its reconstruction at the receiver must be accomplished in one twenty-fifth of a second and if we assume that the number of units per picture is 120,000, the average duration of each impulse will be  $120,000 \times 25 =$

# DRAWING A PICTURE WITH ELECTRONS

I  
part of a second, assuming a change of 3,000,000 light value in each unit. Actually in practice this is not the case for there are considerable expanses of equal tone value though it will be evident that in any ordin-

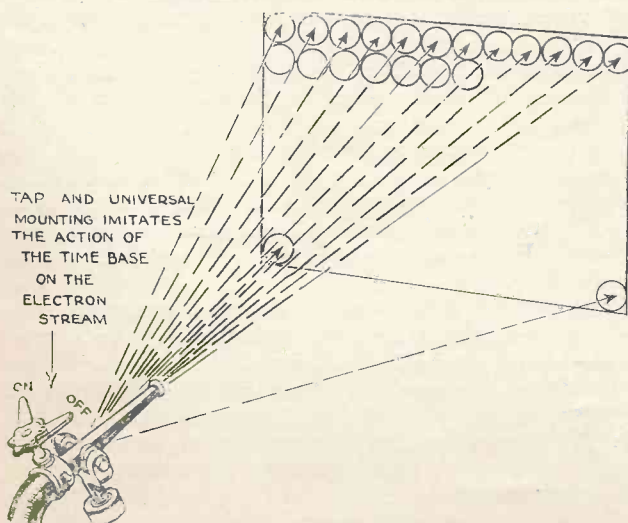

A spray analogy of a beam or "jet" of electrons. Suitable motion of the jet will enable the screen to be covered with a series of lines and if the density of the stream could be varied from instant to instant an image could be produced.

any picture or scene the duration of the impulses must be a very minute fraction of a second.

We can now consider what are the requirements of a television receiver. In the first place it must be capable of picking up the broadcast vision signals, which as we have seen must of necessity be of a very high order of frequency; it must be capable of amplifying these and then of converting them into corresponding values of light; in addition it must be capable of placing these light values on a screen in the correct sequence and at the correct time to correspond with those at the original scene.

## The Cathode-ray Receiver

There are many ways of carrying out these requirements, but for the purpose of this explanation it will only be necessary to consider the type of receiver employing a cathode-ray tube. It is not possible to provide a simple analogy of the cathode-ray tube, but some idea of the purpose it fulfils in a television receiver will be obtained from the following; imagine a device which is capable of projecting a fine jet of spray, so fine in fact that the area is less than a pinhead. If this device were to be set up before a screen and then be moved from left to right it would draw a line of a thickness equal to the diameter of the area of the spray. Now assume that the spray was moved at an incredible speed from right to left and in a slightly downwards direction. The result would be that owing to its speed of travel there would be practically no trace of its return journey and it would, in fact, by giving it suffi-

cient speed be possible to cause it to leave no visible indication in one direction. The result would then be that the jet would be ready to again start its left to right travel and draw another line below the first and this sequence of events could be carried out until the whole area of the screen had been covered with a series of closely adjacent lines.

Now imagine that we had a tap which from instant to instant would control the amount of spray that was being projected, at some times cutting it off entirely and at others allowing varying amounts of spray to pass. The result would be that some sort of image would be produced which would consist of varying values of light and shade or, if the tap were controlled in some proper ordered sequence, a picture could be produced.

It will be apparent from this analogy that one way of producing a picture is by means of a fine spray, which is moved in a proper sequence provided that means are provided for varying the density of the

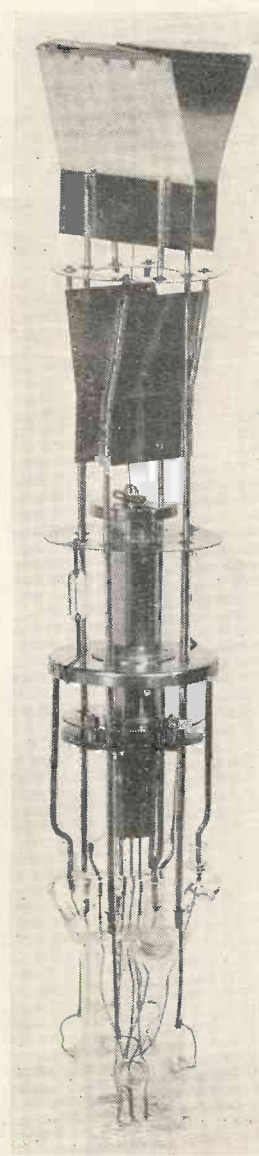
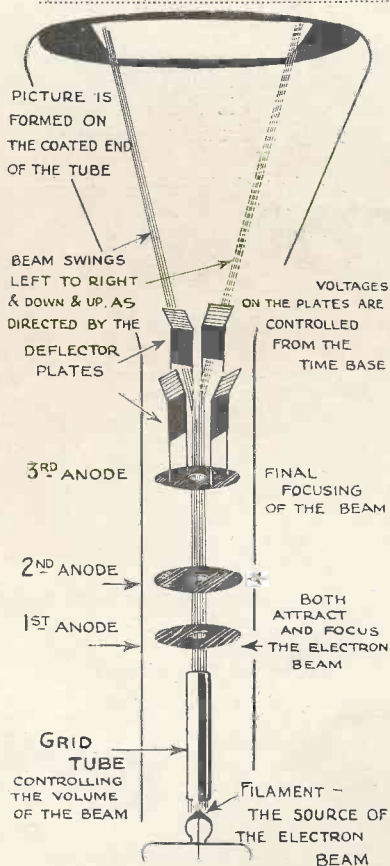

Here is a diagram of a cathode-ray tube showing the arrangement of the electrodes. The photograph shows the electrode assembly of a typical tube employed for television reception.

## REQUIREMENTS OF A TELEVISION SYSTEM

spray. Obviously the movement of the spray is a condition that can be fulfilled locally; it could be set up on some oscillating stand and would work automatically, and we can imagine that the control of the tap governing the rate of emission of the spray could be made from outside, as for instance by means of electrical impulses. It would, most probably, be quite impracticable to make such a piece of apparatus work for a variety of reasons, chief of which would be the inertia of the spray, but it has been found possible to produce an electrical device which is almost a counterpart. This device is the cathode-ray tube, and for the spray it produces a beam of electrons that are weightless and therefore possess no inertia. Complete appreciation of this fact is of the utmost importance for it is difficult to imagine anything which is possessed of weight moving at the incredible speeds that are necessary in television.

In the cathode-ray tube then we have the means available of producing a jet of electrons and by means of an exterior, but local, device causing this jet to move from left to right, and then right to left in a slightly downwards direction at a greatly increased speed repeating the process until a screen of the desired size has been covered. The jet then returns to its original starting point and the whole process is repeated, each complete repetition representing a frame or picture. This action is termed scanning.

Electrons are quite invisible, but their presence can be revealed by causing them to strike a specially prepared screen which fluoresces under their impact.

The exact rate of emission of the electrons can be controlled so that instant to instant during the travel of the electron beam its density is varied, and consequently the amount of light which is produced on the

screen due to its impact. Actually this control is obtained from the incoming signals.

It is possible to cause the beam to move from side to side with a very high degree of regularity, but not quite so regularly as is required for television and it is found necessary to apply a correcting impulse at the end of each line and the completion of each frame.

Before considering the actual apparatus employed it will be well to summarise the requirements which have been dealt with in the foregoing. Firstly, there is the provision of a beam of electrons which can be made to strike a specially prepared screen and reveal its presence by the production of light.

Secondly it is essential that this beam can be caused to scan, in a proper sequence, a predetermined area. Both these conditions are fulfilled locally; that is they are quite independent of any outside influence such as transmissions.

Thirdly, the density of the beam of electrons must be capable of variation from an outside source, as for example the received signal impulses.

Fourthly, the speed of travel of the beam must be exactly the same as that at the transmitter. This is secured by setting the beam to run at approximately the correct speed and applying received impulses at the completion of each line and each complete frame.

These requirements necessitate the use of special apparatus which may be roughly divided up into a number of units as follows: In the first place there is the aerial and a special type is employed called a dipole which is desirable on account of the ultra high frequencies that are employed in television. Next there is the receiver which is very similar to an ordinary wireless receiver; in addition there is a separate receiver

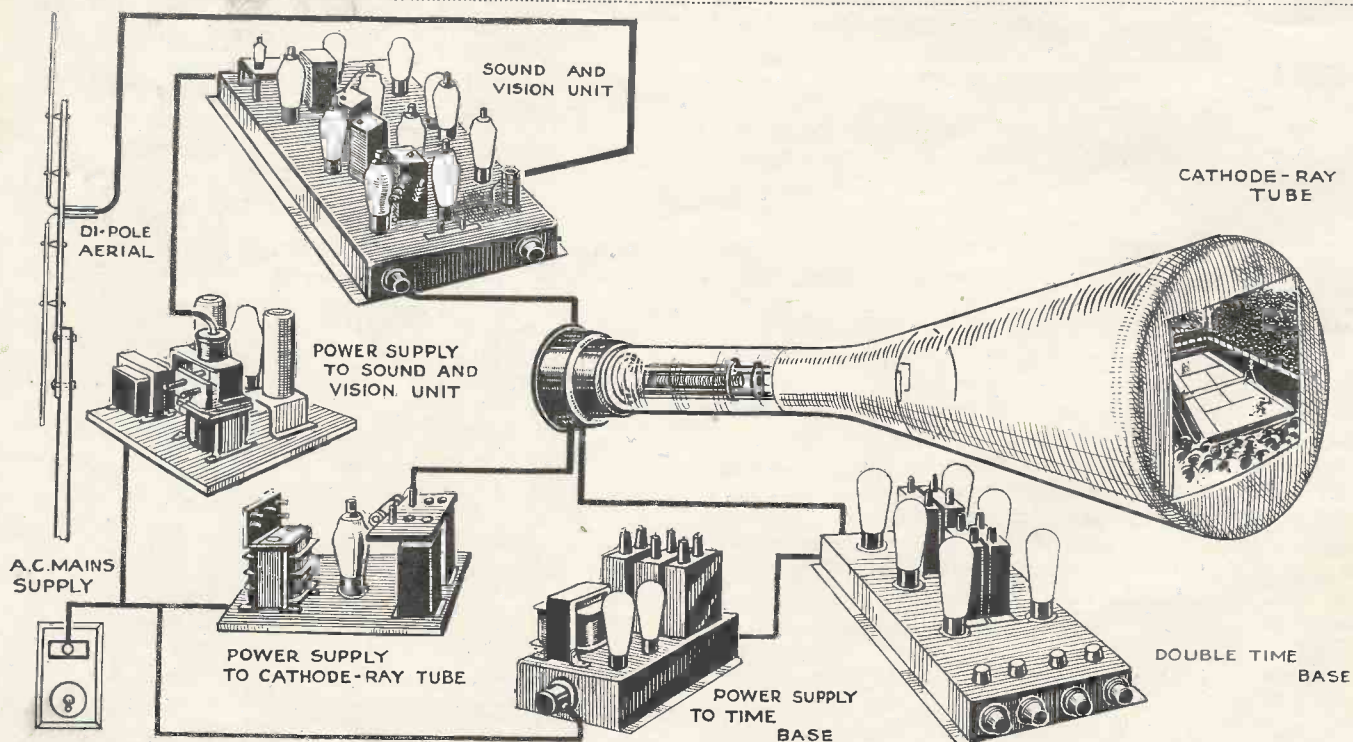

This is a schematic diagram of the units usually employed in a complete cathode-ray receiver. It will be seen that the sound and vision receivers are built on the same chassis and that they have a common power supply, an arrangement which is optional.



## THE CATHODE-RAY TUBE SIMPLY EXPLAINED

for the accompanying sound transmission. The receivers, of course, require high and low tension supplies and it is usual to provide a power pack for these. The most important item is the cathode-ray tube which will be described in detail later. As this is very similar to a large valve, power supplies, both high and low tension, must be provided for it, and as the former is usually of the order of three to four thousand volts a special power unit is required. It has been explained that the movement of the beam is a local condition and to accomplish this a special unit called a time base is provided and this also must be provided with high and low-tension power supplies. It will be clear, therefore, that the television receiver as a whole consists of a number of units which employ ordinary radio principles.

### What the Cathode-ray Tube Is

As the heart of a television receiver is the cathode-ray tube it will be useful to consider this first. The cathode-ray tube consists of a large pear-shaped glass vessel containing an electrode assembly. Both its construction and functioning are very similar to the ordinary wireless valve. For the electrode assembly of the cathode-ray tube there is a glass pinch which carries the filament, which is the source of electron supply; a cylindrical electrode called the grid, which has a similar function to the grid of a valve; and an anode to which the electrons are attracted. Actually in most modern tubes there are three anodes, one serving to accelerate and the other two to focus the beam to a fine point on the end of the tube. In order that the electrons can reach the screen at the end of the tube, each anode is provided with a hole through which they can pass.

The purpose of the electrodes so far described is to provide a beam of electrons and give these sufficient velocity so that they will strike the end of the tube where their presence is made visible by causing the specially coated surface to fluoresce.

For television purposes it is necessary to be able to vary the density of this stream of electrons so that the amount of light caused by their impact on the prepared screen will vary accordingly. This is the function of the grid, or Wehnelt cylinder as it is sometimes called, and it acts in the same way as does the grid of a valve.

Additionally, there are two pairs of plates called deflectors placed beyond the final anode, and if suitable potentials are applied to these it is possible to cause the electron beam to swing about in any direction and at any speed.

The elementary points to remember are (1) that electrons are produced by means of a filament which may be either directly or indirectly heated; (2) that these electrons can be made to take a beam form; (3) that the density of the beam can be varied within very wide limits; (4) that the electrons composing the beam can be accelerated by using successive anodes to which high electric potentials are applied; (5) that the beam can be swung about at high speeds by applying potentials to suitably disposed deflector plates.

The electrons leave the filament and pass to the first anode, some of which, owing to their high speed, pass through, though the majority pass to the metal of the

anode and form an anode current as in the ordinary valve. If, however, a negative bias is applied to the cylindrical grid or control electrode, this will have the effect of compressing the stream of electrons and therefore more will pass through the hole in the anode and very few remain on the metal. If the grid bias is increased considerably, the stream will be cut off altogether and it is this property of the grid which is used to vary the intensity of the electron stream and so produce varying light on the screen.

After the electrons have passed through the hole in the first anode there is a tendency for the beam to diverge instead of remaining in a compact jet and it is necessary, therefore, to bring them together again, and this is accomplished by applying a high potential to the second anode, the compression actually being brought about by the electric field which is produced between the first and second anodes.

The beam is caused to swing from side to side and move downwards line by line by applying a rapidly changing potential to pairs of deflector plates. The scanning circuits, or time bases as they are termed, to provide this changing potential are designed to produce the deflection regularly and uniformly one in one direction and the other in a direction at right angles.

In operation for television purposes the signal from

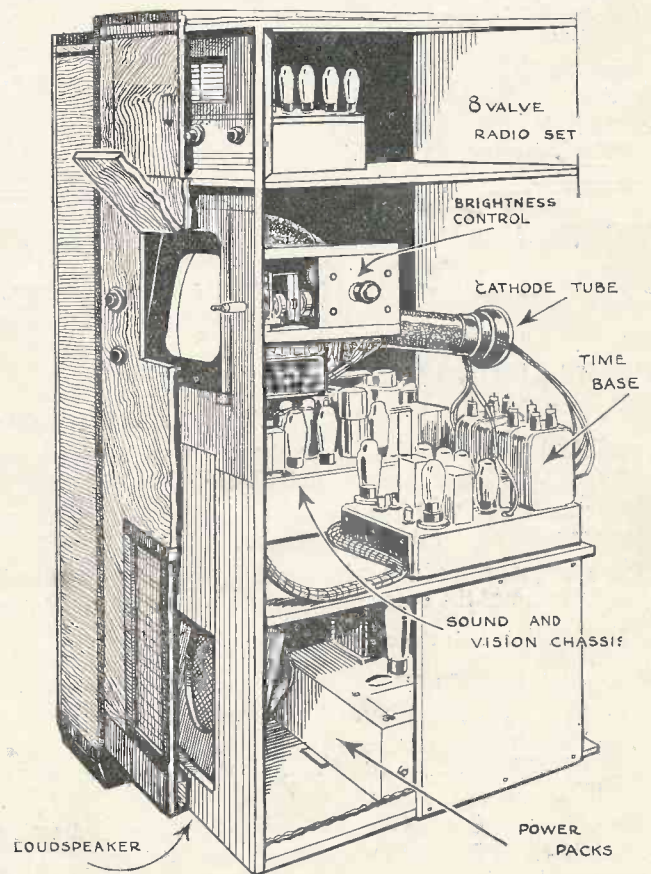

A cut-away view of a television receiver incorporating an all-wave radio set showing a typical arrangement of the various units employed in its construction. This is the direct viewing G.E.C. receiver.

the receiver is applied to the grid of the tube whilst the beam is tracing the screen, and this modulates the intensity of the beam which is revealed as a varying intensity of light on the screen.

It is most important to obtain a thorough idea of the units of which the complete receiver consists and at the risk of repetition we can summarise them as follows:

Sound receiver } and associated low- and high-  
Vision receiver } tension supplies.  
Cathode-ray tube and necessary low- and high-  
tension supplies.

Time bases and necessary low- and high-tension supplies.

These units need not be separate and it is common practice to combine some of the power packs, and also the sound and vision receivers are often built on one chassis.

There is no mystery about the vision signal receiver for it follows ordinary wireless practice with the difference that the output instead of being fed to a loud-speaker is applied to the cathode-ray tube. The fact that it operates on very low wavelengths calls for some special features of design but this does not affect the principle. There are two types of vision signal receiver—the straight set and the super-het—the latter being the more usual type.

For the purpose of this simple explanation there is no necessity to go into the details of the time bases; it will suffice to say that the construction of this unit follows radio practice though it has no counterpart in the ordinary wireless set. The time bases are nothing more or less than resistance-coupled networks using as a rule six valves of special types. The function of the time base is to provide a regular sequence of potentials to the deflector plates of the cathode-ray tube in order

to produce the correct scanning motion of the electron beam.

The time bases are entirely automatic in operation and as has before been mentioned they will cause the beam to move in the required directions with very great regularity. This regularity, however, is not sufficiently accurate so the synchronising signal which is transmitted at the same time as the vision signal is picked up by the vision receiver, filtered out after the second detector, and applied to the time base where it provides just the requisite amount of check to correct any inaccuracies of scanning speed produced in the latter.

As the time base employs valves it needs a suitable power supply and this again is a unit similar to that supplying high- and low-tension for the sound and vision receivers.

As mentioned before, it is necessary to supply high-tension and filament current for the cathode-ray tube. The high-tension is of the order of 3,000 to 4,000 volts, but its provision follows conventional radio practice. The tube power pack consists of a mains transformer, with very high insulation between windings, two valve rectifiers and two smoothing units. Two smoothing units are included because every trace of mains ripple must be smoothed out otherwise its presence will be revealed on the cathode-ray tube and the picture marred.

It will be clear that the complexity of a television receiver is largely due to the fact that before transmission the picture has to be split up into small units which must be reassembled in proper sequence and in the proper time at the receiver. If the picture could be transmitted as a whole as in cinema projection, then the processes involved would be very much more simple and the television receiver would probably be no more complex or more costly than the ordinary broadcast receiver.

## SPECIAL ANNOUNCEMENT.

# A NEW UP-TO-DATE LOW-COST TELEVISOR

We are in the happy position of announcing that

Next Month's Issue of "Television and Short-wave World,"

published on Wednesday, September 29th, will contain the first of a short series of practical home-constructional articles (copyright and exclusive) on *A TELEVISION RECEIVER OF AN ENTIRELY NEW DESIGN*.

It is a self-contained and complete televisor with provision for using a separate sound receiver or a short-wave converter for use with any ordinary broadcast receiving set.

The performance of the televisor if built to our specification and instructions will reach a high level. Here we sum up briefly some of the outstanding advantages possessed by our new televisor:

**LOW COST:** It is the cheapest televisor yet offered to the public.

**65-MILE RANGE:** Tested at this distance from London.

**SIMPLE UNIT CONSTRUCTION:** Does not need special skill in its building.

**PRE-SET TUNING:** Ensures simple operation.

**HOME-CONSTRUCTED COILS:** Anybody can make them and at low cost.

**AMPLE RESERVE OF POWER:** Provided by three H.F. stages.

**LOW NOISE LEVEL:** Sensitivity at long range.

**HOME-BUILT CHASSIS:** Built with the simplest tools.

**NOVEL SYNCHRONISING SYSTEM:** Unaffected by local interference.

**STANDARD COMPONENTS:** Obtainable from stock.

**STANDARD VALVES:** Stocked by most local dealers.

Note that we start the description of this new and unique televisor in the October issue of "Television," price 1/-, on sale on **WEDNESDAY, SEPTEMBER 29th**. In that issue we shall publish a general description of the televisor and devote detailed attention to the vision-receiver part of the equipment. Our instructions will be *simple to understand and easy to follow* and will be fully illustrated by photographs and layout drawings and details.

Ask your Newsagent **NOW** to reserve you a copy.

# EXPERIMENTAL MINIATURE TELEVISION

Last month an article discussed the possibility of making a miniature television receiver using the R.C.A. 1-inch cathode-ray tube. Experimental work has been started on this and we are giving our readers the benefit of our experience in making the apparatus.

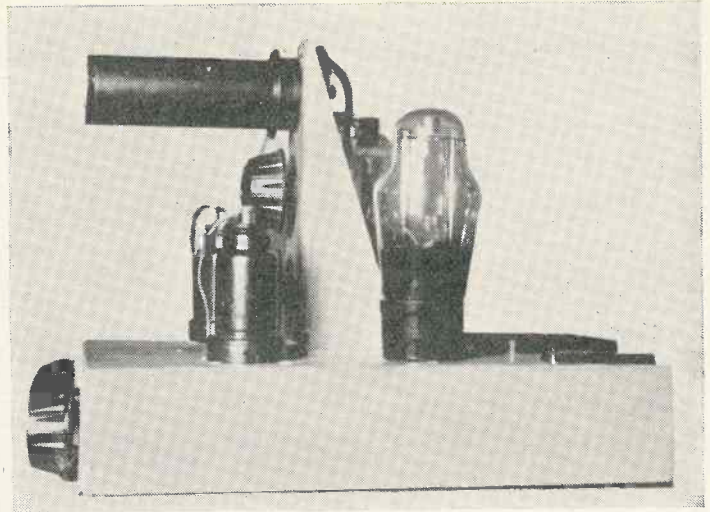

Fig. 4.—A side view of the time base with tube mounted.

THE first investigation undertaken was that of the time-base circuit as it was considered that this could be easily checked by using a standard receiver tuned to the B.B.C. transmissions. The H.T. supply to the tube was obtained from a conventional rectifier circuit conforming as closely as possible to the author's specification. The diagram of the power supply unit is shown in Fig. 1, and it will be seen that extra smoothing is used.

When first switched on a peculiar phenomenon on the part of the 1 in. tube was noted. The screen was covered over the central portion by a space charge which prevented the spot reaching the screen and produced the effect of a black area surrounded by a halo. This is specifically mentioned in the instruction leaf-

let accompanying the tube as follows:

"Under some conditions of operation, especially with low anode supply voltage, a portion of the viewing screen may not fluoresce. This effect, due to a negative charge when the velocity of the electrons is too low, may be prevented by inserting a switch in the negative lead or by setting the control-grid bias for beam current cut-off until the anode voltage has risen to its full value."

This immediately suggested the cause of the trouble and the H.T. voltage was checked and found to be only 320. The value specified is 350, and on raising the H.T. to this value the spot was obtained without difficulty. This point is worth noting, as a choke of high resistance in the supply unit may give rise to excessive

voltage drop and produce the same effect.

With 350 volts, as specified, the brightness of the spot did not appear to be sufficient to warrant a good picture when the full scanning lines were applied to the tube. As is known, there is a considerable reduction in intensity between a stationary spot and a line traced at 10,000 cycles, and it was decided to increase the available tube voltage to 400 to obtain a brighter picture. At the same time minor modifications were made to the supply circuit. The reservoir condenser was kept at 4 mfd., but the chokes were increased to 20 hy. and an extra 8-mfd. was added to the output. It was later found that the load of the scanning circuit was such that there was a tendency for the voltage to fluctuate with the low-frequency

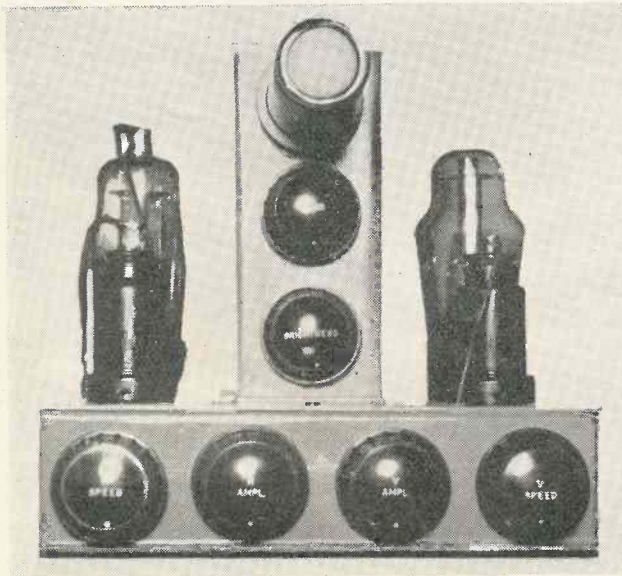
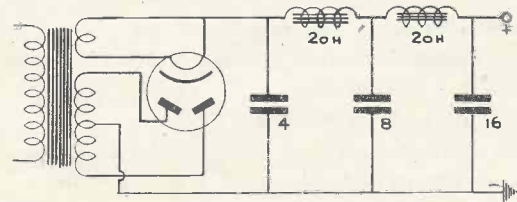

Fig. 5 (left)—Front view of tube and controls.

Fig. 1 (above)—Circuit of H.T. supply unit for tube and receiver.



scanning speed and the additional condenser cured this. The total consumption of the scanning circuit is approximately 16 mA, and it would be preferable to tap the H.T. for the video amplifier from the first choke to provide higher voltage and a degree of decoupling.

The specified H.T. resistance chain for the tube differs slightly from that given in the R.C.A. instruction

leaflet, but both give equally good results. The one given by the author is shown in Fig. 2, and the additions made after experimenting are shown by the dotted lines. The grid resistance was replaced by one of 10,000 ohms to give finer adjustment, the original value of 25,000 ohms being made up by a fixed resistance. Tubes appear to differ considerably in characteristics, as one required only 15,000 to avoid cut-off of the beam. The inclusion of condensers between the anode and grid taps and the cathode is accepted practice in this country, and with the common H.T. supply circuit used definitely improves the focusing of the tube.

**Time Base**

Two time-base circuits are specified by the author, the first of which was given in last month's article and is reproduced here (Fig. 3). An experimental chassis was designed which would enable the circuit to be rewired to the other if required without spoiling the general layout of the components. This chassis is shown in the photographs of Figs. 4 and 5. The tube is mounted on a stand in the centre, the spacing being such that the screen comes level with the edge of the chassis when in a cabinet. The controls for the focusing and brilliance are on the same stand below the tube and are fitted with extension handles when in place in the cabinet. The two time-base valves are on each side of the tube, and the controls for the time-base on the lower flange of the chassis. The original valves specified were the 88g thyatron, and the type 58 pentode, both of which are difficult to obtain. Accordingly, the chassis was wired for British thyratrons (Mazda T31, or Osram GT1B), and the all-metal type 6K7 was used as a substitute for the 58. The difference in heater voltage necessitates the provision of separate windings on the transformer and separate contacts on the multi-contact plug connector, but the aim was to follow the specification as closely as possible.

Constructors intending to make up the unit may use all-British valves, such as the AC/S2Pen, or MSPen 4. The circuit shown in Fig. 3 presents one or two novel features. Owing to the fact that the pentode is used for charging, the condenser  $C_p$  and its associated thyatron are "up in the air," and the return from the deflector plate is made to H.T. + instead of to the -ve. as is more

usual. It must be remembered that the circuit is running with the cathode earthed and the positive supply lead is, therefore, live to the chassis as in the conventional radio set.

The grid of the thyatron is tapped to the same point in the potentiometer chain as the screen of the pentode, and when the condenser  $C_p$  is charged, the grid bias is thus equal to the difference between the anode and screen voltage of the pentode. This value is non-adjustable and gave

(Continued on page 528)

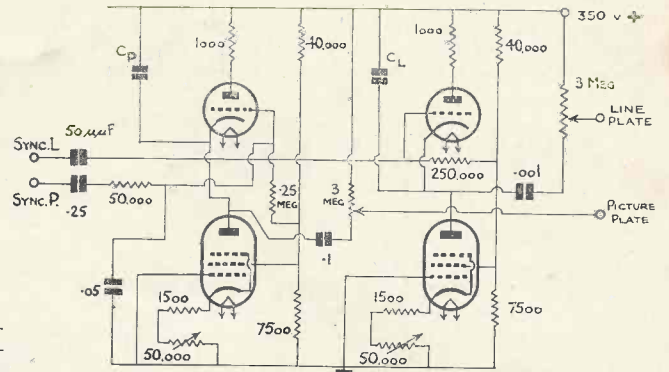

Fig. 3.—The original time-base circuit.

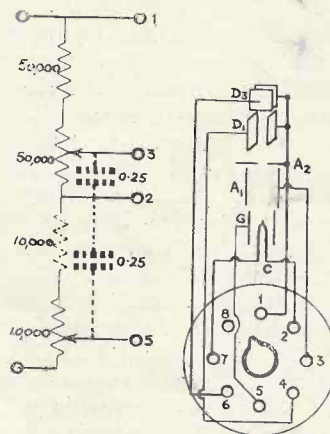

Fig. 2.—Resistance chain for tube supply and tube base connections viewed from pin end.

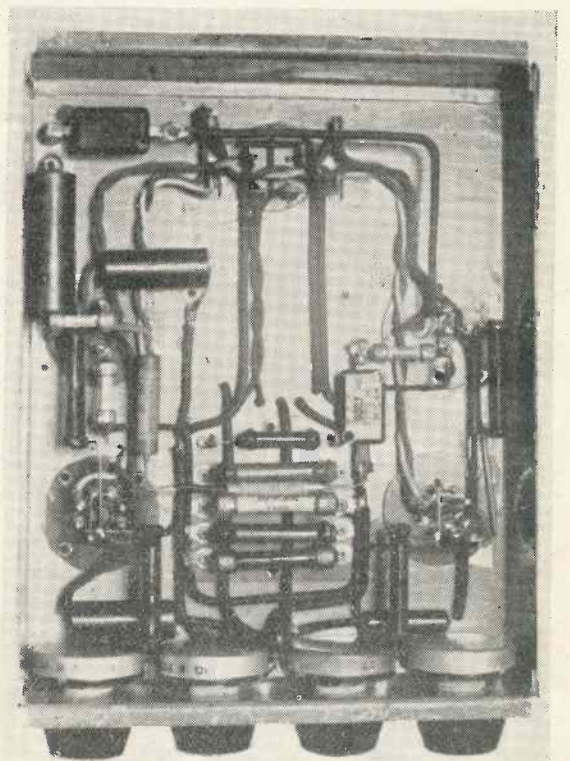

Fig. 7.—Underneath view of time-base chassis

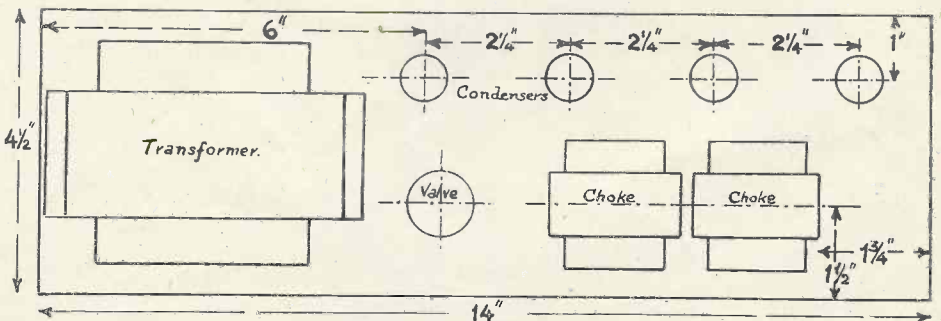

Fig. 6.—Layout of chassis—H.T. unit. The chassis is bent out of 16 g. aluminium with 2 flaps.

# BAIRD TELEVISION LTD.

**WORLD PIONEERS & MANUFACTURERS OF  
ALL TYPES OF TELEVISION EQUIPMENT**

★ **FIRST IN 1926** ★

★ **FINEST IN 1937** ★

Brilliant pictures, freedom from distortion, excellent detail, wide angle of vision, extremely simple operation, high fidelity sound and all-wave radio are among the factors contributing to the first-class performance of all Baird Television receivers. Incorporating all the latest features in television development, every model in the range represents the high-water-mark of achievement.

★ ★ ★ ★

Each television receiver incorporates a Baird "Cathovisor" Cathode Ray Tube which has the outstanding advantage of being completely electro-magnetic in operation. These tubes can be supplied separately with the necessary scanning equipment where desired. Apart from manufacturing processes, stringent tests are made for electrical emission, tube characteristics, filament rating, and screen quality; and following normal picture reconstitution under service conditions, every Baird Cathode Ray Tube, on completion, is subjected to a very high external pressure test. Baird "Cathovisor" Cathode Ray

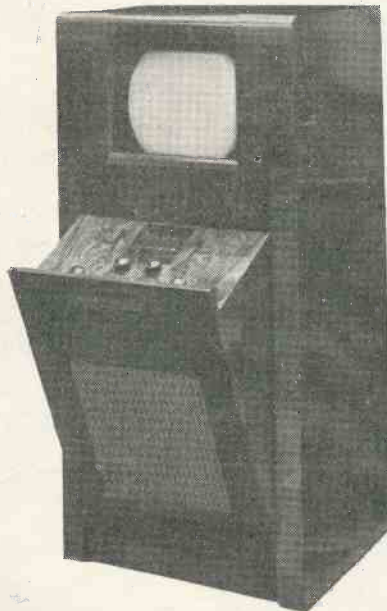

One of the New Baird Receivers  
Model T11

**A cordial welcome is extended to every reader to visit STAND No. 87 at Radiolympia.**

**New receivers and other equipment will be featured on the company's stand.**

Tubes are the ideal solution for high quality television pictures.

★ ★ ★ ★

A large number of Flat installations have already been undertaken by the company, and amplifier equipment for this purpose is now available. Vision and sound are provided "on tap" in any room desired, and technical advice will be given by the company's experts on all points.

★ ★ ★ ★

Another new development is the Baird Multiplier Photo-electric Cell, of which there are two main types, suitable for either a concentrated light beam or diffused light. The Baird Multiplier is a chain of electron permeable grid stages, and under service conditions current gain factors of the order of 100,000 can be obtained. Cathode sensitivity is approximately 30 micro-amps per lumen. These Multiplier Cells are suitable for all television and sound on film work, together with many industrial applications where high gain, coupled with sensitivity and extremely high signal to noise ratio, is essential.

Head Office :

**Greener House, 66, Haymarket,  
LONDON, S.W.1**

'Phone: Whitehall 5454

Laboratories :

**Crystal Palace, Anerley Road,  
LONDON, S.E. 19.**

'Phone : Sydenham 6030

# When at RADIOOLYMPIA



... DO NOT FAIL  
TO VISIT THE

## Osram Valves STAND...

where you will see the complete range of Valves for Broadcast reception on all wavelengths, the most up-to-date Valves for TELEVISION, Tuning Devices, and Valves for Commercial and Industrial purposes of every description.

MADE IN ENGLAND

Advt. of The General Electric Co. Ltd., Magnet House, Kingsway, London, W.C.2.

# TELEVISION SIGNALS ACROSS THE ATLANTIC

By H. O. PETERSON and D. R. GODDARD  
(Research Engineers R.C.A. Communications, Inc.)

An exclusive account of some R.C.A. experiments in picking up the B.B.C. Signals in New York.

ON January 21, 1937, one of the engineers at the Frequency Measuring Laboratory of the Radio Corporation of America at Riverhead, N.Y., was making his usual routine "cruise of the ether" in the neighbourhood of 40 megacycles when to his surprise he heard a carrier modulated with a voice having a distinct English accent. A hurried check of the frequency showed the carrier to have a frequency of 41.5 megacycles per second, the assigned frequency of the voice channel of the Alexandra Palace television transmitter.

This was the start of a series of observations and measurements on the English and German television transmissions. Fig. 1 shows the ultra-short wave receiver used. The lower panel of the further rack is the

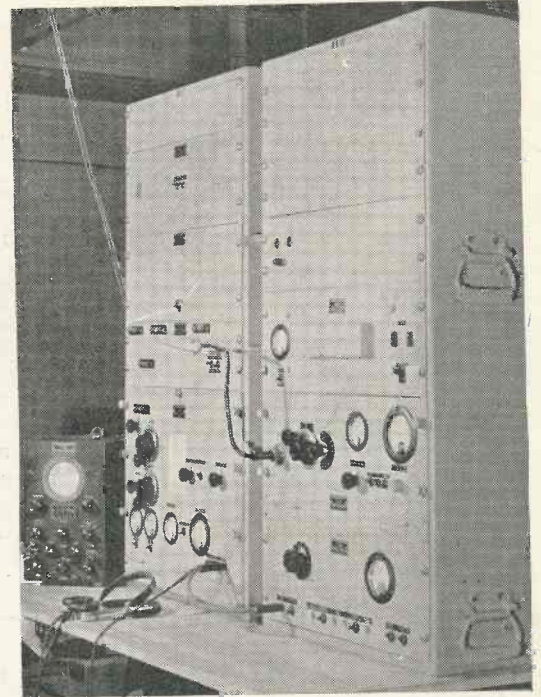

Fig. 1.—The receiver used in New York for picking up the Alexandra Palace signals.

controlled double-pole double-throw switches were installed and connected as shown through transposed transmission lines to a third similar switch located near the centre of the antenna. From this third switch a transmission line was run to the receiver, shown in Fig. 1. The object of this array of switches was to provide means whereby the receiver could be connected to either end of the antenna and a damping network connected to the other end. This provided a directive antenna directed towards London or, at the snap of a switch located at the receiver, a directive antenna aimed 180° away from London.

From January 21 to April 4, the voice channel from London was heard 45 times whilst the video channel was heard 15 times. Usually the signals were rather weak, but at times both the audio and video channels became quite strong. The maximum field strength observed was about 70 microvolts per metre for both channels. As the rhombic antenna used had an effective height of about seven metres, the signal strength at the terminals of the receiver approached 500 microvolts.

## German Transmissions

The German and French television transmissions were heard on several occasions but in general these signals were not as strong as the English transmissions and were heard less consistently. There was also reason to believe that the Italian television voice channel was received although positive identification was not established.

The English signals were picked up a few times at the R.C.A. receiving station near Chicago. The signal strength at this point was considerably weaker than at Riverhead (near New York City). Also the

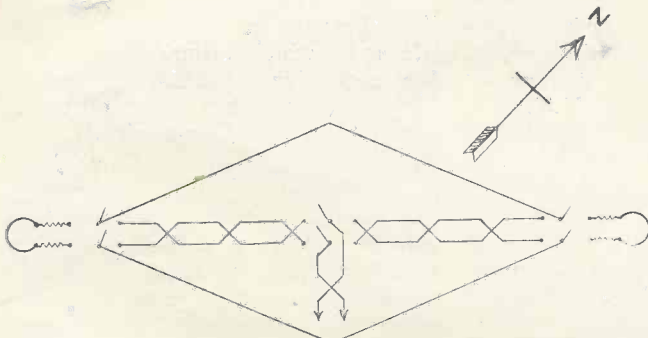

Fig. 2.—Diagram of horizontal rhombic antenna for receiving Alexandra Palace on 41.5 mc.

receiver proper while just above it is a low capacity antenna switch used to connect the receiver to either the incoming transmission line or to a calibrated ultra high-frequency signal generator contained in the rack in the foreground. The bottom panel of this rack is a peak voltmeter useful in comparing peak signal values and determining signal-to-noise ratios. The upper panels of the two racks contain the rectifying equipment and voltage regulators necessary to obtain stable receiver operation at these frequencies.

Fig. 2 shows the horizontal rhombic antenna designed to receive London on 41.5 mc. At the two extremities of the antenna special low-capacity remotely

signal often was not audible at Chicago when Riverhead would have a good signal.

Unfortunately, during the period of maximum signal strengths, there was no television receiver available on which to observe the video signal capacity. When such a receiver was procured the period of strong signals had passed and there was not sufficient signal voltage to permit proper kinescope synchronisation. However, judging from the fact that at times the received video signal reached a value of well over 400 microvolts, it would be reasonable to assume that a useful picture could have been obtained. The audio signal frequently was of sufficient strength to give excellent loud-speaker reproduction.

These two channels were, of course, subject to fading. This fading was of quite a different nature on each. The 41.5 megacycle signal usually experienced rather rapid deep dips in intensity, in fact, it seldom maintained a fixed value for more than a few seconds at a time, while the 45 megacycle channel changed its level slowly, frequently remaining almost constant for a minute or more. Rarely was the fading of a selective nature on the audio channel. The audible response of the video

channel was of such a nature as to make it difficult to state whether or not selective fading was present.

One case of interference from another station was noted. This signal came from a ship off the coast of Scotland working the shore with their standard ship telegraph transmitter operating on 8.3 megacycles. It was the fifth harmonic of the transmitter that caused the interference.

### Is Transatlantic Television Possible?

The reader now probably wonders if this is the start of regular trans-oceanic television. In the opinion of the authors this phase of television is still distant. The trans-oceanic reception of frequencies of 40 to 45 megacycles may be explained as being due to exceptionally high ionisation of the  $F_2$  region of the Kennelly-Heaviside layer. This in turn is in phase with the great increase in sunspot activity as the maximum of the eleven-year sunspot cycle is approached. With this in mind it is reasonable to assume that for the next few years, there will be sporadic reception of ultra-high-frequencies over great distances.

### "Experimental Miniature Television"

(Continued from page 524)

rise to difficulty. The values of the components were such that with the thyratrons used the sweep was non-linear and several alterations had to be made. Reduction of the lower resistance (7,500) improved the sweep but altered its timing owing to the alteration of screen voltage.

The resistances in the cathode circuit of the pentodes were also found to be too coarse for convenience and were replaced by variables of 10,000 ohms, the balance, where necessary, being made up by fixed resistances. Condenser  $C_p$  was set at 0.1 mfd., which then gave a 50 cycle sweep at a reasonable setting of the potentiometer. Condenser  $C_L$  was tentatively set at .0003 mfd., but this is critical and the setting of the screen potentiometer system completely alters the speed of the scan.

Before giving final details of the time-base suitable for the B.B.C. transmissions the second circuit, which is on more usual lines, will be tried and a full report given next month.

### H.T. Unit

In the meantime, the details of the H.T. unit are given as this is quite satisfactory and is not affected by the choice of time-base.

The layout of the chassis is shown in the diagram of Fig. 6. The specification of the transformer is as follows, with the reservation that the heater windings will be modified to

suit British or American valves. It is important to note that a centre tap for the heater of the tube is *not* required, and if this is provided it should *not* be connected to chassis as the cathode is already connected inside the tube. Other heater windings can have the centre point earthed as usual.

Transformer: Primary 0-200-220-240.

Secondaries:

6.3 v. 0.6 amp. for tube heater.

6.3 v. 1.5 amp. for time-base valves.

6.3 v. 5.0 amp. for receiver.

4.0 v. 2.0 amp. for rectifier.

4.0 v. 3.0 amp. for thyratrons.

400-0-400 v. 60 ma. for H.T.

Chokes: 2 Bulgin Type 20 H. 50 ma.

Condensers: 1 Dubilier 4 mfd. 500 v. wkg.

3 Dubilier 8 mfd. 500 v. wkg.

Sundries: 5-pin valveholder, fuse, mains switch and 8-point connecting plug and socket (Bulgin).

The layout is given in the diagram and the construction is simple and calls for no comment. To make a neat job of the connections from the 8-point plug the heater leads from the transformer should be soldered to a terminal plate under the chassis.

This can be made from a strip of paxolin with eyelets riveted or screwed on it. The rectifier is a Mazda UU.5 or Osram U.12.

### A Useful Encyclopaedia

Some eighteen months ago Messrs. Hutchinson produced a "Technical & Scientific Encyclopaedia" in four volumes at a price of £5. The entire stock of this publication has now been purchased by the Phoenix Book Co., of Chandos Street, who are offering them at a reduced figure of £2 15s., which brings them within the reach of many readers who might hesitate over such a heavy outlay as the original publisher's price.

The books are attractively printed and up-to-date in their information, and provide a most useful source of concise information on subjects allied to electrical engineering and physics. All the technical terms used in mining, metallurgy, chemistry, and building are given with sufficient information to enable the reader to understand the particular section of the subject to which he is referring.

In radio, articles have been contributed by such well-known workers as Mr. L. H. Bedford, Dr. H. M. Barlow, Dr. R. L. Smith-Rose, and many others.

The encyclopaedia can be confidently recommended as a handy work of reference for the research worker's library. The Phoenix Co. are prepared to arrange deferred terms if desired.

**Our Stand  
at Radiolympia is  
No. 105.**



# Scannings and Reflections



## PROJECTION RECEIVERS

THE "surprise" item at Olympia is the Philips' projection receiver which produces a picture 20 in. by 16 in. on a flat screen, or alternatively, on to a screen separate from the receiver and up to 3 ft. square. Although this is the only commercial model of this type on show it is not the only one that has been produced in this country. Several other concerns, notably Bairds, have been giving a great deal of attention to the possibility of projection and a considerable amount of research work has been done. No doubt the interest shown in Germany in this type of receiver will provide a fillip for more intense investigation of its possibilities.

## FOREIGN INTEREST

Radiolympia this year is attracting a greatly increased number of foreign visitors, chiefly from France, Germany and the United States, and the reason is television. With our experience of a year's transmissions and the commercial production of receivers which can actually be placed in the hands of the public with every degree of confidence, the foreigner feels that there is certainly a vast amount of valuable data to be obtained. The indications are that television will prove the greatest attraction of the show.

## ALTERATIONS AT THE PALACE

During the three weeks' holiday period when the normal transmissions from the Alexandra Palace were closed down, work on a considerable amount of structural alterations has been carried out. Chiefly this has been concerned with better studio facilities, particularly the entrances and exits which formerly were very cramped. Preparations have also been made for the use of a second studio which will enable better continuity between items to be obtained. Also the opportunity has been taken to overhaul the transmitting gear.

## ROOSEVELT AND TELEVISION

In a message which President Roosevelt sent to the National Broad-

casting Company of America, he emphasised the importance of the development of television by saying: "I believe that sooner than many of us realise television will be established in homes throughout this country. Indeed it may not be long before television makes it possible to visualise at the breakfast table the front pages of the daily newspapers no matter how remote we may be from the place of their publication and distribution."

## "BEHIND THE BEYOND"

A play within a play will be televised on September 10 and 14 in the evening and afternoon programmes respectively, when Stephen Leacock's problem play "Behind the Beyond" will be presented. "Behind the Beyond" takes the form of a commentary by a sophisticated man of the world who sits beside us, as it were, in a theatre, and describes the pulsating drama enacted before an audience "buzzing with brilliant conversation, illuminated with flashes of opera glasses and the rattle of expensive jewellery, with here and there the crackle of a shirt front."

Multi-camera work and a battery of sound effects will, it is hoped, convey the authentic atmosphere of the stage and auditorium. At the end the audience are saying as they surge out in great waves of furs and silk that it is a perfectly rotten play but very strong. But, as the narrator reminds us, just inside the theatre in the office is a man in a circus waistcoat adding up the "ready" with a blue pencil, and he knows that the play is all right.

## TELEVISION SPEEDS

A Cossor television engineer has made some interesting calculations of the speeds employed in television. An extraordinary number of different things happen all at once so often and the speeds are enormous.

Taking as a basis 25 pictures per second and each picture made up of 405 lines, the length of time taken by the cathode beam to scan one line is one 10,125th part of a second. If

we take the length of a line as being 10 inches, this represents a speed of 5,750 miles an hour. Put in another way, travelling at the same speed, New York would be only thirty-five minutes from London!

Television transmission is on a frequency of 45 megacycles. (This is the same thing as saying 45 million cycles. Our calculations will show, therefore, that one line occupies 4,444 cycles. If we take the diameter of the spot at 1/50th of an inch, we find that the actual width at any point on the screen represents nine cycles of the carrier wave.

Fast as these speeds are—fantastic perhaps you may think—they are leaden-footed compared with the actual electrons which form the cathode beam. These have been calculated to travel at 66 million miles an hour. Put in another way, an electron could travel 2,750 times round the Equator whilst you were enjoying your mid-day 60-minute break!

## RADIOLYMPIA AERIAL AND FEEDER SYSTEM

The Baird Company have executed the whole of the work in connection with the design and installation of the aerial, feeder and distribution system used for the fourteen television demonstration rooms at Radiolympia. The aerial position on the roof of Olympia was determined after exhaustive tests to enable the maximum signal to noise ratio to be secured. From the Baird aerial and feeder the television signals pass to an E.M.I. amplifier after which connection is made to a specially designed Baird distribution box having thirty outlets. From this box two feeder cables pass to each television demonstration room. Every precaution has been taken to ensure that there is the minimum risk of breakdown.

The Baird Company are to be congratulated on having secured such an important contract from the R.M.A. for the television demonstrations have proved to be the outstanding feature of this year's Radiolympia.

## MORE SCANNINGS

### INCREASED RANGE

Almost every day brings news of reception at distances greatly in excess of the original conservative estimate of thirty miles. Range varies with location, but excellent reception has been obtained at distances up to fifty miles in most directions and in many cases far in excess of this. The G.E.C. have obtained some valuable data on this matter and are prepared to advise upon the possibility of good reception up to distances greatly in excess of the commonly accepted service range. No one within a distance of seventy miles from the Alexandra Palace need regard reception as impracticable.

### NEWS BY TELEVISION

A television system has been developed in America for the dissemination of news only. (This is the Peck system and it is intended to send out news flashes, headlines and bulletins. The received images consist of moving letters on a strip. The news items are typed out on a special machine at the transmitting end and then scanned by mechanical methods. Reproduction is by means of a mirror drum, the system being entirely mechanical. It is proposed to rent the receivers and include advertising with the news bulletins.

### HUNT BALL PROGRAMME

Harry Pringle, who devised the successful "Cabaret Cruises" in

television, has hit upon the happy idea of staging a Hunt Ball in the studio, with a pack of real hounds to give the final touch of realism. The studio will be decked out as a typical country house, where the company will be making merry in preparation for the next morning's meet. (This programme will be presented in the autumn.

### PICTURE PAGE

Miniature editions of the popular feature "Picture Page," devised by Cecil Madden, are to be presented between August 25 and September 1. Elmina Humphreys, the 19-year-old girl, who has been chosen to represent the spirit of radio, will appear in "Picture Page" during the afternoon and evening of August 25. Other regular television features which viewers will see at Radiolympia are "Coffee stall," "The Television Follies," the first concert party regularly to be televised, a trio of skaters, Charlie Higgins, the Lancashire comic, and some more dancing lessons. Viewers should make a special point of seeing Joan Collier and Elizabeth French, who are to be televised on August 31 and September 1 respectively.

### SUNDAY TELEVISION

There is every possibility of Sunday television, for a proposal to introduce an hourly programme on

Sundays is under consideration. It appears that the only stumbling-block is the usual question of money, but should the Government give a further grant to television from the radio licences then television on Sundays will be almost a certainty.

### O.B. TRANSMISSIONS

The television outside vans are to be put to good use in the near future. Mr. Gerald Cock is planning a number of very interesting outside relays, while next year the Boat Race relay is to be a high-light with a close-up of the winning crew. There will also be a tour of the King George V Dock, while viewers will also be taken to a London film studio.

### TELEVISION IN BIRMINGHAM

By the end of this year the coaxial cable between London and Birmingham will be in operation. This cable, primarily intended for telephone work, will make it possible for a television station to be erected in Birmingham. As usual, the only hold-up is likely to be financial rather than technical, but should the B.B.C. have sufficient money, then Birmingham television enthusiasts will shortly have transmissions.

### THE PHOTO-SENSITIVITY OF SELENIUM

In the August issue was an article relating to the discovery of the photo-sensitivity of selenium by Willoughby Smith and Mr. Joseph May. The following information will probably interest our readers:

As Chief Electrician of The Telegraph Construction and Maintenance Co., Ltd. Mr. Smith was intimately concerned with the development of submarine cables, and it was in designing a high resistance for connection to the shore end of a cable during the laying and testing thereof that he hit upon the idea of using selenium. The resistance of this material was found, however, to be very variable, for some unknown reason, and experiments were therefore conducted to ascertain the cause. Mr. Joseph May, who was Mr. Willoughby Smith's chief assistant, and who in 1882 became chief of the electrical department of the company, was instructed to fit up the system at the works and to report, and it was during these experiments that the photo-sensitivity of selenium was observed.

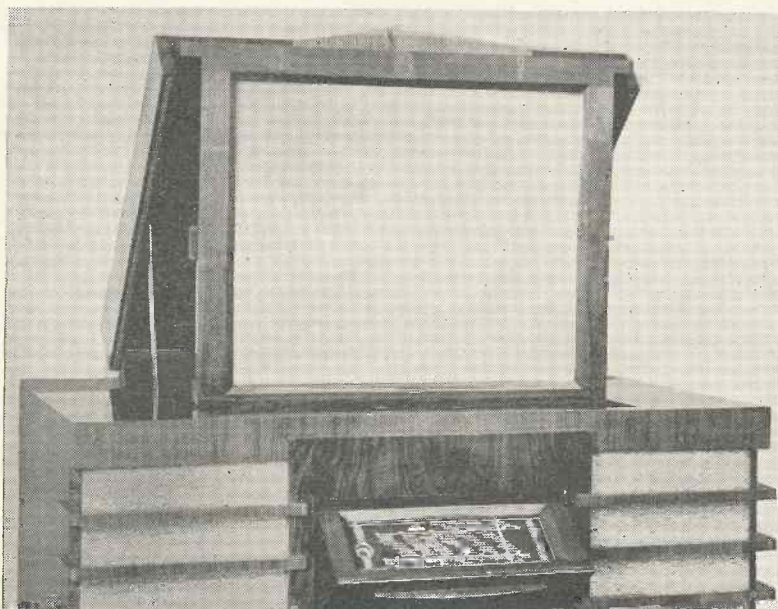

The upper part of the Philips cathode-ray projection receiver. A description is given on page 546.

**AND MORE REFLECTIONS**

Mr. Willoughby Smith communicated these results to the Society of Telegraph Engineers by letters dated February 4, 1873, and March 3, 1876, and read a paper before the Society on November 28, 1877.

**A G.E.C. SURPRISE**

In addition to the three G.E.C. television receiver models described in the show report pages of this issue, we understand that visitors to Radiolympia will also be able to see an advance model of an entirely new departure in television design which will be on the G.E.C. stand. This will be a table model in the low-price class, and it is stated that it will be on sale by the end of the year.

**RECEPTION ON 10 METRES**

Unexpectedly, reception conditions on 10 metres seem to be improving. We were interested in a British station, G6DH, who in a very few moments worked an Australian, Japanese and an American station. Although this band has been so dead for the past few months, stations are now coming through more like the 20-metre band, so that before long more records will probably be broken by the speed at which amateurs are

able to work all continents on 10 metres.

While on the topic of reception conditions, most listeners are more cheerful owing to the fact that stations on 20 metres are now coming through quite regularly and at very good strength. For those who listen in the morning, it is quite a common occurrence to hear upwards of a dozen Australian stations, and all sorts of out-of-the-way signals not normally heard. (The owner of a modern all-wave receiver can at the moment rest assured of world-wide reception.)

**ALL-WAVE RADIOLYMPIA**

Never before have those interested in short-wave reception been so well looked after by manufacturers than at the present time. At Radiolympia almost every set-maker has designed at least one good all-wave receiver. The problems of band-spreading and simple short-wave tuning have been carefully gone into, so that most commercial receivers to-day are suitable for serious short-wave reception. In many instances receivers tune down to 11 metres, while in some cases the minimum wavelength covered by a standard family receiver is no less than 4.8 metres.

and also gives the A. T. & T. Co. the use of the Farnsworth system.

It is interesting to note that the Bell Laboratories can now pursue research on the cold cathode Farnsworth "multipactor" tube for the use of this tube in the wide field of communications.

**Scophony, Ltd., and Radiolympia**

Scophony, Ltd., recently made public the fact that while receiving apparatus employing the Scophony methods has been designed and constructed for the reception of the present Alexandra Palace transmissions (on the 405 line standard), they have found that there was a considerable amount of irregular timing and phase shifting in the synchronising signals radiated from Alexandra Palace, which made such signals unsuitable for receivers using scanning systems possessing inertia. Representations were made early this year on the subject to the Television Advisory Committee and the B.B.C., and the B.B.C. has taken steps to remedy the defect.

The B.B.C. have now informed Scophony, Ltd., that a completely new pulse generating equipment is in the course of construction and will, it is anticipated, be installed and working towards the end of this month. It is pointed out by the B.B.C. that in the case of such a complicated piece of apparatus, certain adjustments may be necessary, but Scophony, Ltd., have been assured that the B.B.C. will take all possible steps to ensure that the signal radiated is in such a form as to satisfy their requirements.

Scophony, Ltd., regret that as this new Alexandra Palace equipment will not be ready in time for Radiolympia, they will be unable to demonstrate there the Scophony Home Receiver (giving a picture 24 in. by 22 in.) and small Public Hall Receiver (giving a picture 5 ft. by 4 ft.). They hope, however, to be able to give public demonstrations on such receivers and to announce the marketing arrangements for same, as soon as possible after the new Alexandra Palace pulse generating equipment has been found to work satisfactorily.

**Farnsworth Television and the American Telephone and Telegraph Company.**

An agreement has been entered into between the American Telephone and Telegraph Company and Farnsworth Television, Incorporated, which will lead to co-operation between the Bell system, Farnsworth, and certain Farnsworth licencees, and clarify a difficult patent situation.

In an exclusive interview with a Farnsworth official, our correspondent has been informed that this agreement permits an interchange of patents and technique between the two companies and their research laboratories.

The American Telephone and Telegraph Company dominates wire communication, both telephone and telegraph, in the United States, as it were, and maintains the Bell research laboratories, one of the foremost

laboratories in the field of communications research in the world. The A. T. & T. Co. has done considerable television research itself in the past, but now has full access to the Farnsworth system, one of the two basic modern electronic television systems.

The Farnsworth laboratories will continue research in the field of television and cold cathode "multipactor" tubes, and Philo T. Farnsworth will continue as head of the laboratories and direct the research.

In bringing electronic television out of the laboratory into the field of experimental communications, one of the problems confronting Farnsworth engineers was the fact that A. T. & T. Co. held certain patents. These patents were not so much in the field of television proper, but rather in the broader field of communication. This agreement removes these obstacles

Read **Television and Short-wave World** Regularly

# RADIOLYMPIA ITS PICTURES AND RECEIVERS

Arrangements for visitors to see the television demonstrations at Radiolympia are of a much more elaborate character this year than last. Fourteen theatres are provided each of which will seat about forty people and instead of only being allowed a comparatively brief glimpse of the pictures each viewer will be able to watch a fifteen minute programme in comfort. The duration of these programmes has been arranged as far as possible so that every viewer will be able to see a varied programme giving some indication of the possibilities of television. On this account therefore the programmes will be divided as nearly as possible into five minute features. These are to include variety, ballet, drama, an outside broadcast from the Pets Corner at the Zoo and various displays staged in the grounds of the Alexandra Palace.

## PLAN SHOWING THE POSITION OF THE TELEVISION DEMONSTRATION THEATRE

Free Demonstrations Daily, from August 25 to September 4, 11.30 a.m. to 12.30 p.m., film; 4 p.m. to 5 p.m., actuality transmission; 9 p.m. to 10 p.m., actuality transmission.

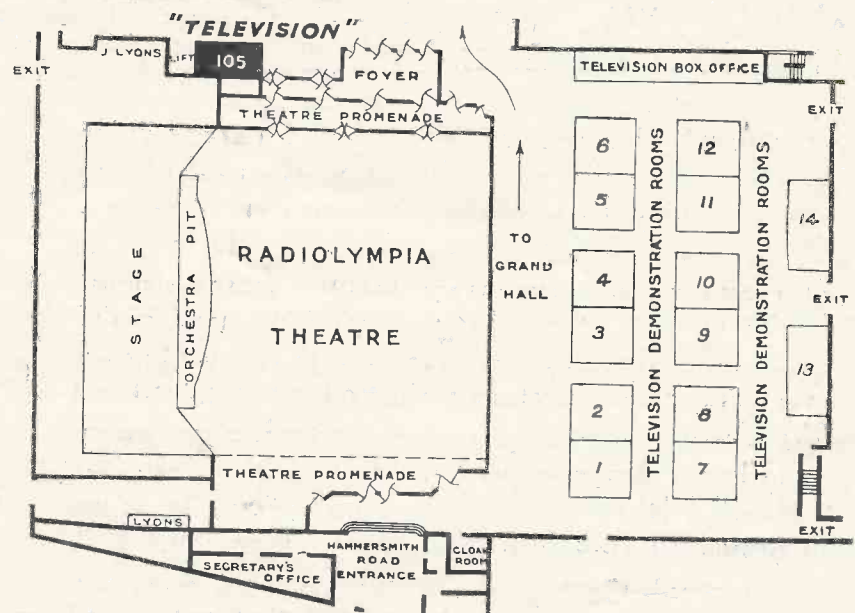

## TELEVISION RECEIVERS AND APPARATUS AT OLYMPIA

**BAIRD TELEVISION, LTD., 46, Haymarket, London, S.W.1. Stand No. 87**

Baird Television, Ltd., feature an entirely new range of receivers and equipment on their stand.

Each receiver incorporates a Baird "Cathovisor" cathode-ray tube, which is completely electro-magnetic in operation. Both the 12-in. and 15-in. tubes can be supplied separately with the necessary scanning equipment where desired.

The Model T.11 television receiver is designed to give the maximum of home entertainment under a wide variety of conditions.

The black and white pictures, 10 in.

by 8 in. in size, are viewed directly on the horizontally mounted 12-in. diameter "Cathovisor" cathode-ray tube. The brilliance of the picture is of a high order and it may be viewed either in daylight or with ordinary room lighting. The viewing angle is adequate for all normal room purposes.

An all-wave broadcast radio receiver and loudspeaker form a completely self-contained unit accommodated on the front panel of the cabinet. This is hinged out when in use so as to allow complete operation

of the radio controls. The cabinet is of high-grade walnut.

The Model T.12 television receiver has been designed to meet the needs of those viewers who require a large size television picture together with a high quality all-wave radio receiver. It is a luxury set appealing to those who desire outstanding performance at a moderate price.

The black and white pictures, 13½ in. by 10½ in. in size, are viewed in a hinged, part mirrored lid, the 15 in. "Cathovisor" cathode-ray tube being mounted vertically on the left

**OUR STAND IS No. 105 ADJOINING THE THEATRE**



# Look behind the picture

A superficial critic might class all cathode ray tubes as pretty much alike. The observant technician looks deeper, and considers such matters as the maintenance of spot shape and focus; the straightness of the modulation characteristic, which controls the true degree of light and shade; even light distribution and adequate brilliancy over the entire surface; the stability and life of the screen; accuracy of spot centering and other details. Marconiphone, in their Emiscope Cathode Ray Tubes, have achieved the best practical combination of these important features, embodying a combination of magnetic scanning with a unique hexode electron gun and an exclusive method of screen formation.

Two sizes are available — and two screen materials:

Type 6/1 9" green	Type 6/3 12" green
„ 6/2 9" white •	„ 6/4 12" white
List price - 11 gns.	List price - 15 gns.

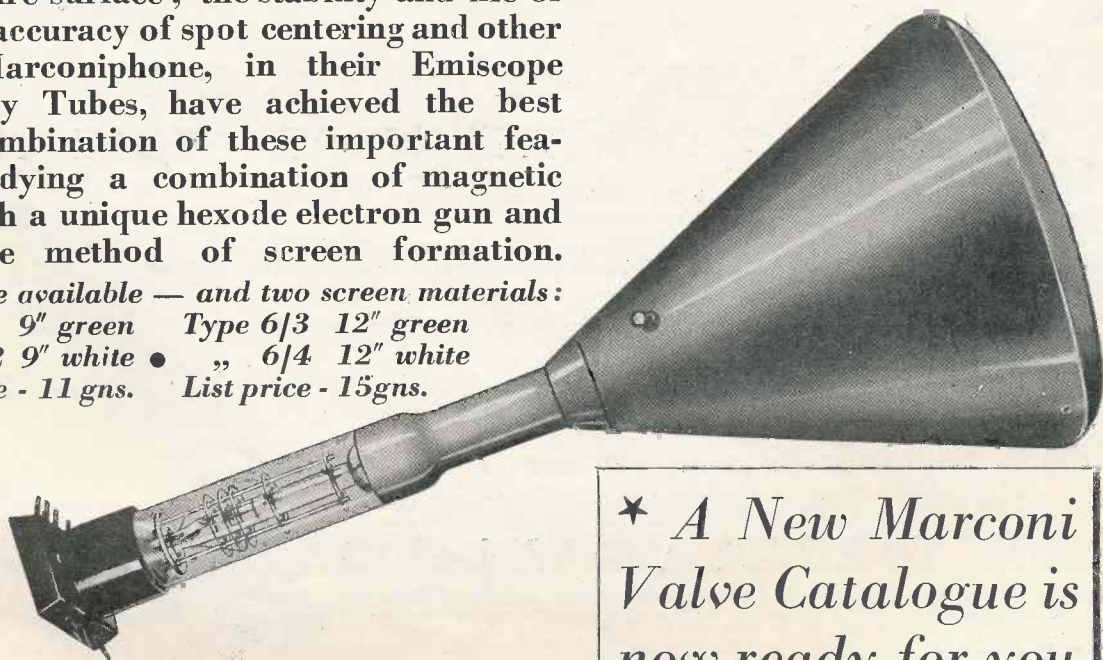

\* A New Marconi  
Valve Catalogue is  
now ready for you

Write for full details to Valve Sales Section

**THE MARCONIPHONE COMPANY LIMITED,**  
Radio House, Tottenham Court Road, W.1.

## BAIRD AND COSSOR

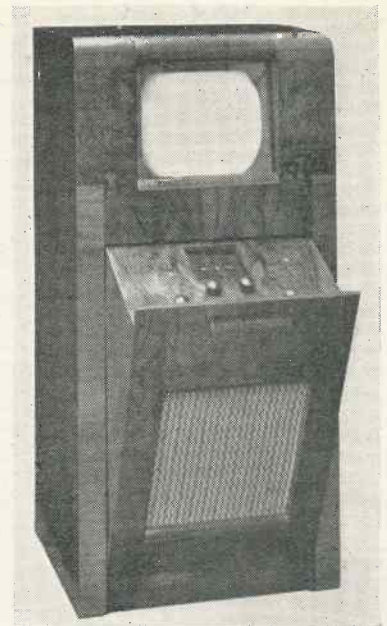
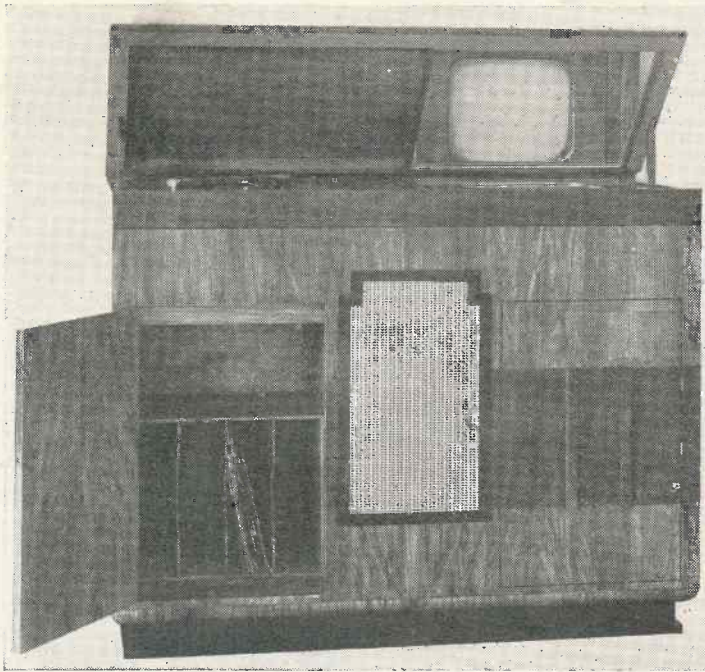

Two Baird receivers, the model T 13 and the model T II

of the cabinet and covered with a window of safety glass set flush with the cabinet top. This picture, the largest yet shown on this type of Baird cathode-ray tube, represents the most modern practice.

By the operation of a single switch the instrument is converted to an all-wave broadcast receiver covering short waves (16.5 to 51 metres), medium waves (198 to 550 metres), and long waves (850 to 2,000 metres). This superheterodyne receiver has an output rating of 8 watts giving ample loudspeaker volume for every possible occasion without any trace of blasting.

The Model T.13 receiver is a luxury television receiver, a high fidelity all-wave radiogram with a Collaro auto-

matic record changer capable of playing any size records indiscriminately and either a fitted cellarette or record cupboard, according to purchaser's requirements.

The black and white picture, 13½ in. by 10¼ in. in size, is viewed in a hinged, part mirrored lid, the 15-in. "Cathovisor" cathode-ray tube being mounted vertically in the cabinet and covered with a window of safety glass set flush in the deck of the receiver. The all-wave broadcast receiver incorporated covers short waves (16.5 to 51 metres), medium waves (198 to 550 metres), and long waves (850 to 2,000 metres). The output is 8 watts. Other features of this set are a large illuminated vernier name dial, variable selectivity

control and a sensitive A.V.C. system. The pick-up of the radiogram has a crystal head.

### Flat Installations

A large number of flat television installations have been undertaken by Bairds and samples of the equipment used, together with a complete layout of a modern block of flats are shown. Vision and sound are provided "on tap" in any room desired, and technical advice will be given by the company's experts on all points.

Another new development is the Baird Multiplier photo-electric cell, of which there are two main types, suitable for either a concentrated light beam or diffused light.

### A. C. COSSOR, LTD., Cossor House, Highbury Grove, London. Stand Nos. 61 & 163

The Cossor exhibit on Stand No. 163 embraces a range of C.R. tubes and instruments, including oscillographs, cameras and amplifiers for cathode-ray recording and test and aligning equipment for the comprehensive servicing of radio and electrical apparatus.

*Oscilloscope Model 3332.*—A complete laboratory equipment in compact form for use on radio and electrical test work. It uses a 4½ in.

diameter cathode-ray tube. Its specification includes high-voltage power pack, signal amplifier of 26 db. gain covering 20 to 100,000 c.p.s., multi-range deflector coils permitting A.C./D.C. measurements of from 1 M/a. to 3 amps., Mumetal shield against electro-magnetic interference, synchronising, shift and calibrating circuits and ruled scale. The sensitivity is 15 M.M./V. A camera specially designed for use with this

oscilloscope model is also shown.

*Ganging Oscillator Model 3343.*—An instrument indispensable to servicemen for the visual alignment of the H.F. and I.F. circuits in radio receivers. A band of from 90 kc. to 20 mc. is covered in five steps. It is both frequency and amplitude modulated (standard 400 cycle note).

*Oscillograph Model 3363.*—The largest instrument of this type constructed; primarily designed for

**EDISWAN AND FERRANTI**

laboratory use and incorporating a 12 in. diameter cathode-ray tube, power pack and hard valve time base.

**Triple Tube Unit Model 3314.**—An equipment designed for the simultaneous recording of three distinct correlated phenomena. This unit is displayed with the film camera Model 3318 and drum camera Model 3317 for use therewith.

**Oscillograph Amplifiers.**

**Audio Amplifier Model 3319.**—Designed for all A.F. recording. The exhibit is shown complete with microphone.

**Paraphase D.C. Amplifier Model 3355.**—This instrument is designed for the recording of a wide frequency range from zero to 100 kc., and is eminently suitable for the investiga-

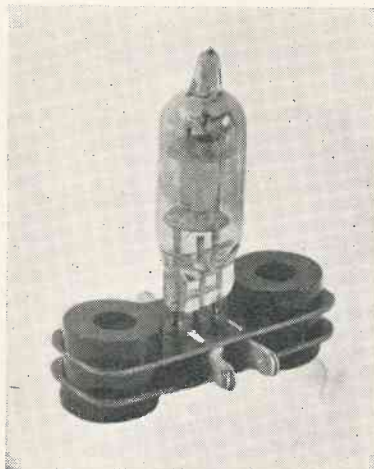

tion of pressure problems. The exhibit shows the amplifier in use with pressure unit Model 3305, bridge element Model 3358, D.C. pre-amplifier Model 3326, and a high-vacuum cathode-ray tube units 3313 and 3345.

**Cathode-ray Tubes.**—A complete

A full-size photograph of the new Mazda television diode. Its small size is shown in comparison with the special Belling-Lee holder for which it has just been released. Further details of both components will appear in next issue.

range of Cossor cathode-ray tubes of the gas-focused and high-vacuum types, directly-heated tubes for oscillography and examples of the new indirectly-heated television tubes are displayed in finished and separate electrode assemblies.

**THE EDISON SWAN ELECTRIC CO., LTD., 155, Charing Cross Road, W.C.2.  
Stand No. 57.**

In addition to the range of electrostatically focused tubes this company have introduced two new magnetically focused tubes for television. These are designated 9.MH and 12.MH, and have screen diameters of 9 in. and 12 in. respectively. The characteristics are as follows:

- Heater volts, 2.0.
- Heater current, 1.5.
- Anode volts, 6,000 max.
- Grid bias, 30-60.
- Max. beam current, 150 uA.

The tubes are fitted with a standard 7-pin base and have screens giving a black-and-white picture.

On the stand a complete television

receiver chassis is mounted to show the component parts and advice is given to intending constructors. The new supplement to the Mazda manual contains a suggested circuit for a television time base using Mazda Thyratrons, and the new output valve AC/P4.

**Receivers**

In the television section of the exhibition this firm are demonstrating two receivers designed by the Research Laboratory of the B.T.H. Co., employing Ediswan tubes and Mazda valves.

These sets are not available commercially at the present time but are

intended to give a guide to constructors of the quality obtainable.

An excellent educational exhibit on the stand is a tube showing how the scanning lines are built up. This is similar to the circuit shown at the Science Museum, which has been scanning steadily for over eight weeks. Another item of interest is a special tube designed to show the colours obtainable from various screen materials. These are coated on the end of a large diameter tube and the spot is caused to scan each band material in turn. It is expected that many of the unenlightened members of the public will think that colour television has arrived!

**FERRANTI LTD., Moston, Manchester, 10**

Ferranti, Ltd., are showing one type of television receiver designed for vision and television sound only. It is of the direct view type, the picture being 11¼ in. by 9 in. of daylight white and black colour. The receiver employs a 15 in. Ferranti cathode-ray tube with magnetic scanning and magnetic focusing, this method having been adopted after a great deal of research and experiment into all systems at present em-

ployed. The pictures are very bright and the magnetic system provides a very fine beam spot so that the resulting pictures are sharp and well defined.

**TELEVISION'S STAND**  
IS  
**No. 105**

**Stand Nos. 21 and 74**

There are eight controls: tuning, volume, bias, contrast, horizontal hold, vertical hold, focus and on-off.

The tuning control automatically tunes in the vision and the remaining controls do not require to be reset after having once been adjusted.

Eighteen valves are used. The sound output is 2½ watts from a pentode to a special compensated large output transformer feeding the speaker.

**THE GENERAL ELECTRIC CO., LTD.**



Two G.E.C. receivers: left, the BT 8121 and right, the BT 8161.

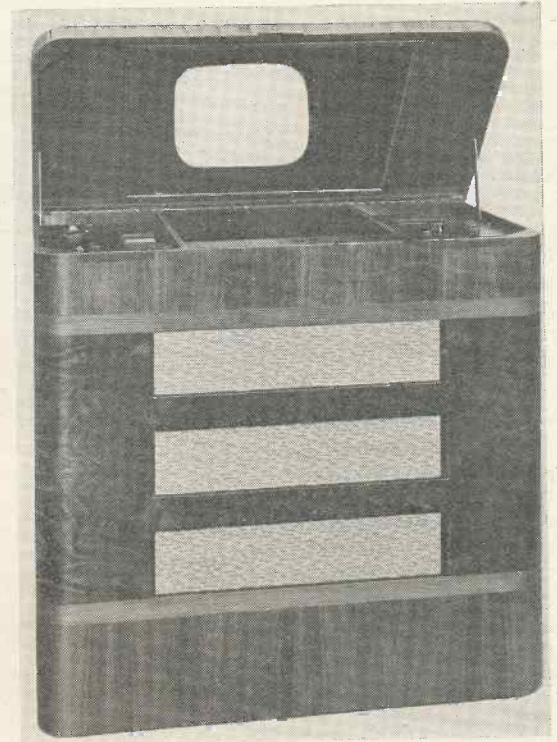

**THE GENERAL ELECTRIC CO., LTD., Magnet House, Kingsway, London, W.C.2. Stands 54 and 62**

The G.E.C. television range will comprise three models as follows:— BT3701 television (sound and vision) receiver, price 60 gns. BT8121 television and all-wave radio receiver, price 80 gns. BT8161 de luxe television and all-wave radio receiver, price 110 gns.

The BT3701 is an instrument designed for television reception only (sound and vision). Direct viewing is used with this model. The tube is mounted nearly horizontally, and provides a picture size 10 in. wide and 8 in. high, with the widest angle of view. Brightness and definition are both exceptionally good, and the operating controls are of the simplest character. A powerful moving coil loudspeaker is fitted, providing a very realistic quality of reproduction. The cabinet is hand-polished walnut. Twenty-two valves are employed and the sound output is 3 watts.

The BT8121 combines faultless television reception with an unlimited choice of sound broadcast pro-

grammes on all-wave radio from all over the world. Mirror-viewing is provided reflecting a picture 10 in. by 8 in. from the vertically mounted cathode-ray tube. The mirror, mounted in the lid of the instrument, is of the front-silvered type to give the greatest optical efficiency without trace of distortion, and is of ample size to allow a wide angle of view at a comfortable eye level. The picture possesses a remarkable degree of brightness and definition, with every gradation of half-tone properly reproduced. The controls, both for television and for radio reception are located on the deck and are of the simplest. The loudspeaker fitted is an auditorium dynamic model, capable of doing full justice to the excellent quality of response obtainable. The entire instrument is contained

in a hand-polished walnut cabinet. The BT8161 model while embodying all the refinements of television and all-wave radio afforded by the BT8121 instrument incorporates a still larger cathode-ray tube, giving a reflected picture size 13½ in. wide by 11 in. high. The degree of definition possessed by the picture is so precise that the instrument is perfectly suitable for use in a small room with viewers close to the mirror-screen, but in a bigger room the brightness and picture area are great enough to entertain audiences of 50 or more.

The sensitivity is of an unusually high order, enabling excellent reception to be obtained right out to the furthest points of the television transmission area.

The instrument is housed in a hand-polished walnut cabinet with contrasting inlays. The G.E.C. have carried out very extensive tests, and information regarding the possibilities of reception in any area will be willingly provided on request.

Read  
*Television & Short-Wave  
World*  
Regularly



**"HIS MASTER'S VOICE" AND HAYNES RADIO, LTD.**

**THE GRAMOPHONE CO., LTD., 89-108, Clerkenwell Road, E.C.1. ("His Master's Voice")**  
**Stand Nos. 66 and 76**

"His Master's Voice" range of television receivers, shown on "His Master's Voice" stand, and in the "His Master's Voice" theatre, includes three models—a complete home entertainer, Model 902 at 120 guineas, autoradiogram with television, Model 900, an all-world radio receiver with television at 80 guineas, and Model 901, a receiver for television sight and sound only, at 60 guineas.

The size of the picture in each instrument is approximately 8 in. by 10 in. The models are particularly easy to handle, only the simplest controls being necessary, and all types are installed by the "His Master's Voice" engineers. The prices include the cost of installation and the erection of suitable aerials within the London service area.

Model 902, the combined automatic all-world radiogram and television receiver, incorporates as well as the television equipment, an eight-record automatic changing electrical gramophone, and a six valve five waveband all-world radio receiver of the usual "His Master's Voice" quality. Model 900 incorporates the same all-world radio chassis, but is not provided with gramophone equipment.

*H.M.V. combined all-world Autoradiogramophone and television receiver Model 902. Television, entertainment from short-wave stations in all parts of the world, electrical reproduction of records which are changed automatically.*

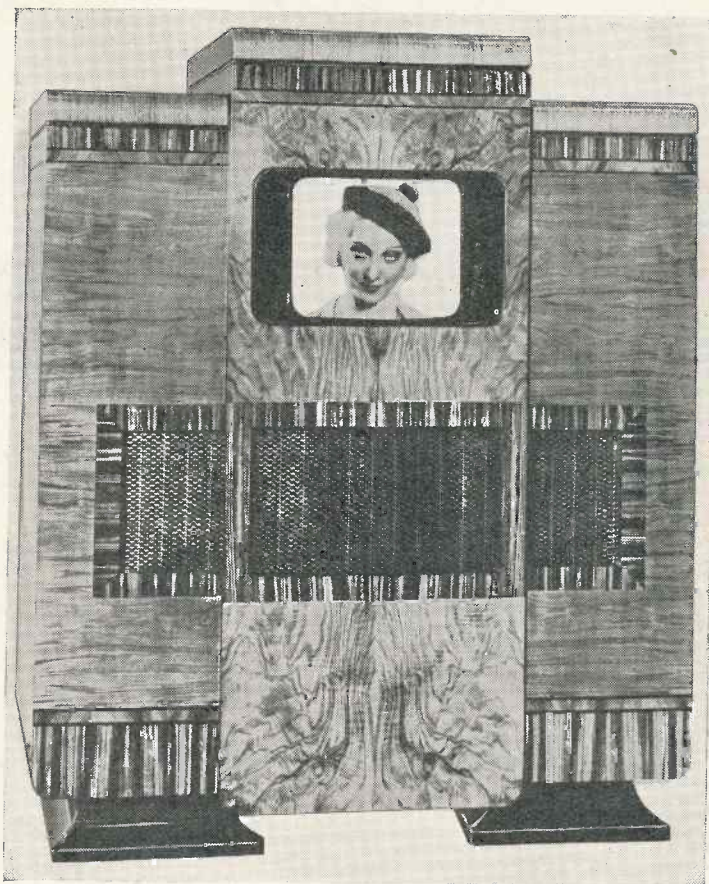

**HAYNES RADIO, LTD., Queensway, Enfield, Middlesex, Stand No. 11**

The Haynes "Viceiver" is a complete television receiver for sound and vision reception, together with medium and long wave reception and gramophone. Direct viewing is adopted. The cabinet is built in three sections, the side compartments carrying radio and gramophone equipment and being of less depth than the centre section, which houses the cathode-ray tube apparatus and loudspeaker.

The cathode-ray tube has a 12 in. diameter screen and is scanned magnetically. The 12-valve vision and synchronising receiver is totally enclosed in an entirely screened unit and has a single limited range tuning control. The price is 120 guineas.

Television apparatus in unit form is available separately.

*(Continued on page 546)*

*The Haynes "Viceiver"*

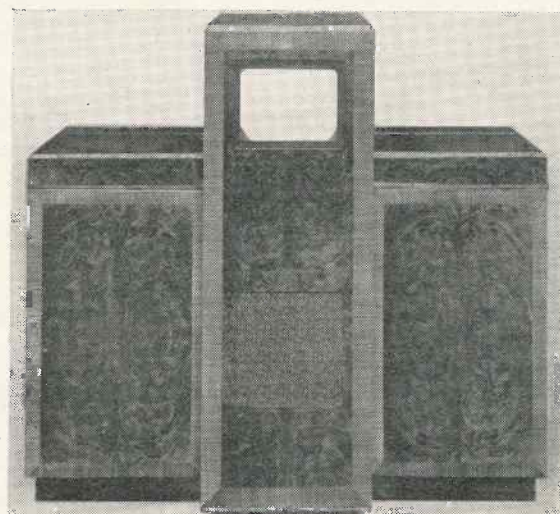

**Television and Short-wave World  
Stand No. 105.**

*The film trade is profoundly interested in television from two conflicting angles. Is it to be a competitor or an*

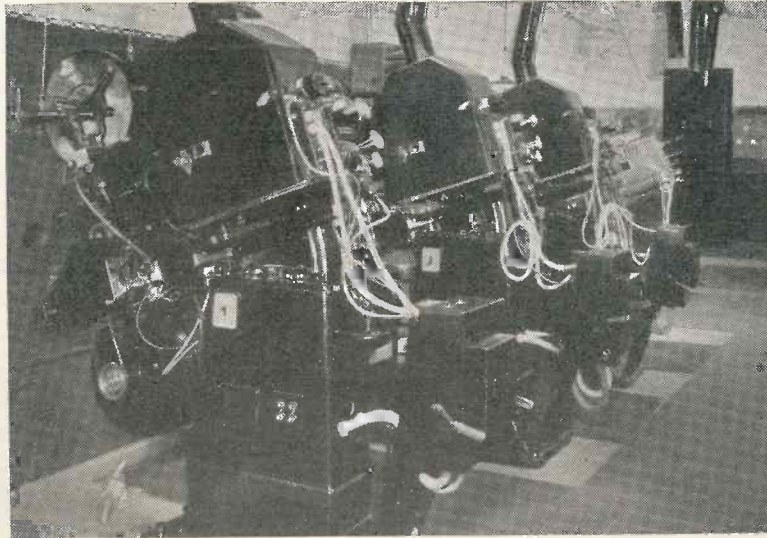

[Photo: Courtesy of J. F. Brockliss, Ltd.]

*ally—a friend or foe? Here are the views of a well-known authority on the kinema.*

# TELEVISION AND THE KINEMA

By R. Howard Cricks, F.R.P.S.

THESE are some film exhibitors who fear that the spread of home television and the cheapening of receivers to bring them within reach of the man-in-the-street will permit people to get their entertainment at home without going to the kinema for it. The more far-sighted exhibitor, however, thinks little of this aspect, but is more seriously concerned with the competition represented by the installation of television receivers in public-houses, clubs, and so forth.

The film trade can do little to stop the progress of home television, but will do nothing to assist it. Film renters have been threatened with dire penalties by exhibitors if they permit their films to be televised; they agreed to the televising of news-reels only by force of the argument that if existing news-reels weren't transmitted, the B.B.C., in response to public demand, would just have to produce its own.

On the other hand, the possibility of their being able to show televised items—particularly red-hot news—on their own screens has induced a minority of scientifically-minded exhibitors to keep in touch with all developments in this new science—one kinema circuit induces its managers and projectionists to take an interest in it by assisting them to buy equipment. This attitude is reflected in the fact that I and other technical scribes of the film trade have kept our readers conversant with all de-

velopments of large-screen technique.

Readers of TELEVISION AND SHORT-WAVE WORLD will be as conversant as I with the present position of the large picture. To summarise: Scophony has demonstrated an excellent 5 ft. picture, and talks of an increase very shortly to 10 ft. and 16 ft. International Television (Mihaly-Traub) have shown pictures several feet in width; Baird claims credit for the first demonstration regularly forming part of a cinema programme—the 8 ft. medium-definition picture at the Dominion, Tottenham Court Road.

The above-mentioned are optical-mechanical systems. I think it probable, however, that ultimately purely electronic systems will be sufficiently developed for the production of large pictures, and in fact from confidential information I have recently received, it appears probable that this stage will be reached considerably sooner than most people think—possibly even within the next few months.

The elementary stage reached in the development of large-screen systems has not prevented kinema exhibitors—a race of showmen—from shouting about it. Of several recently erected kinemas it has been loudly announced that they were to be equipped for television—in other words, space was reserved behind the screen for a receiver. One exhibitor went so far as to claim that he had already come to an arrangement with Scophony—a fact which they modestly refused to confirm.

## Kinema Requirements

Next let me enumerate the requirements of kinema television. They are: (1) A picture of adequate size—not less than 15 ft., and preferably 20 ft. or more in width; (2) adequate illumination—an equivalent intensity of, as a minimum, 2 foot-candles, and preferably 7 or 10; (3) an adequate fineness of definition; (4) an absence of flicker and eye-strain; (5) it would be advantageous if projection, instead of being from behind the screen, could be from the present projection rooms, the sound possibly through the existing reproducing channel.

Sixth and finally—more important than any—is the need for some system of distribution of programmes, which would enable the producer to collect payment from the kinemas. If this cannot be achieved, then there will be little or no kinema television, simply because there will be no revenue to pay for it. Only the B.B.C. can establish the machinery to work on a licence basis, and, except for news, exhibitors won't want to show the same programmes as their patrons can get in their own homes.

## The Question of Definition

The first three points are closely inter-related. The first consideration must be the number of scanning lines.

## WILL TELEVISION SUPPLANT THE FILM?

It is questionable whether the existing standard of 405 lines will be adequate. Capt. West, of the Baird Company, expressed to me some time ago the view that a standard of 700 lines horizontally would give definition equal to that of the present film picture; a little calculation shows this to be the equivalent of a grain size on the film of about .001 in.—a fairly high standard.

Remember, however, that any divergence from the conditions theoretically envisaged—in particular incorrect matching up of scanning lines—will impart an additional lack of definition to the picture.

The problem confronting inventors is then the production of apparatus capable of an accurately scanned 700-line picture, with an equivalent illumination of, at the very least, 2 or 3 foot-candles (a figure which Mr. G. W. Walton, of Scopphony, estimates is obtained on his 5 ft. screen) on a screen 20 ft. in width.

Whether a transmission rate of 25 complete frames per second will overcome flicker is open to doubt. Flicker is, of course, a function of speed and light intensity. Experiments I have recently made<sup>1</sup> indicate that this speed would be adequate in kinematograph projection only for very low values of illumination—possibly not exceeding  $2\frac{1}{2}$  foot-candles. Undoubtedly, however, the present B.B.C. interlaced standard, while not strictly speaking equal to 50 complete frames a second, is considerably better in this respect than 25 non-interlaced frames. No doubt the present figure would prove adequate for the kinema.

These figures are, of course, based on the assumption that phosphorescence is not employed, as with electronic systems it might well be, so materially reducing the minimum number of frames necessary, and also reducing the wave-band needed.

My fifth requirement is self-evident from the commercial point of view; current supplies, sound apparatus, and the projectionists are up in the projection room, while behind the screen are the speakers, and the stage is often needed for presentations and variety turns. But with present scanning systems this would present seri-

ous difficulties of an optical nature.

If, however, some electronic system were adopted, in which a small image, of the order of size of a standard film frame, were the source of the projected picture, the problem could be solved in terms of existing kinematograph lenses, of which commonly used types are made in focal lengths up to 7 in. and 8 in., working at apertures of  $f/2$  and greater.

### Distribution

With regard to the problem of diffusion, I remember that years ago the view of Scopphony was that distribution must be by land-lines. At the time this seemed an impossibility for anything approaching high-definition television, but to-day the only objection to it is cost.

But we are learning more every day about ultra-short-wave transmission, and it seems at least possible that transmission on such waves, complicated by some form of "scrambling," could be adopted, which, in conjunction with a detective organisation similar to that which the film renters now employ to ensure that the terms of their contracts are adhered to by exhibitors, would make surreptitious picking up of the programmes, other than in a purely experimental fashion, very improbable.

That news events will before long be reproduced by television on the screens of news-theatres there can, I think, be no doubt. But a suggestion received with some scepticism by the film trade is that television may one day supplant the film itself—in other words, that instead of showing films, the kinema will merely reproduce a televised programme from some central studio.

The regular transmission, direct from actual production, without the intermediary of a film, of performances can be ruled out for kinema programmes; to meet the needs of the kinema the performance would have to be repeated several times a day, and a number of different programmes must be transmitted simultaneously. Furthermore, anybody who has compared the relative techniques of broadcasting and film production can have no doubt that the latter is better suited to the production of a combined picture and sound entertainment, due primarily to the

wider possibilities of editing and trick-work.

Another point which must not be overlooked is that to all appearances, most films will within the next two or three years be in colour. Colour television is not an impossibility, but it calls for an enormous advance over the possibilities of existing methods; technical difficulties of this nature won't persuade kinema audiences that they prefer black-and-white television to pleasingly coloured films.

### The Commercial Aspect

But, assuming that television were so perfected as to be capable of reproduction equal in every respect to that of direct projection from a film, the whole question boils down to this: a copy of a film capable of being projected hundreds of times costs, say, £50; a television transmission from film (negative) would save the cost of scores of copies, but on the other hand would mean that the exhibitor would have to take the transmission at hours fixed by the transmitting studio.

A time may come when the latter will prove more commercial—for example, in the case of a large circuit of kinemas centred on a small area—but that time is a very long way off. The laboratories that print the films need not consider putting the shutters up yet.

To conclude, I should mention one ingenious application of television to the film which has been suggested by Capt. Round, of Marconi's. He suggests that, instead of filming the actors actually on the studio floor, the picture should be picked up by a television camera and transmitted to a separate recording room, in the same way as the sound is picked up by the microphone and recorded in the sound recorders right away from the actual set. Given a sufficiently high standard of definition, there are certain advantages in such a scheme.

In the various applications I have suggested, there can, I think, be little doubt but that television, far from being a competitor of the kinema, will actually prove one day the kinema's greatest ally. There is in fact every indication that television and kinematography are daily attaining a closer affinity.

<sup>1</sup> See *Ideal Kinema*, May 1937, p. 37, July 1937, p. 45.

# GERMAN TELEVISION PROGRESS

## IMPRESSIONS AT THE BERLIN EXHIBITION

By J. Sieger

THE Berlin Radio Exhibition was fully representative of the present state of electronic television. Due to the facts that the various firms are in one way or another connected with English and American organisations, and that work has been unimpeded by financial considerations, the results shown

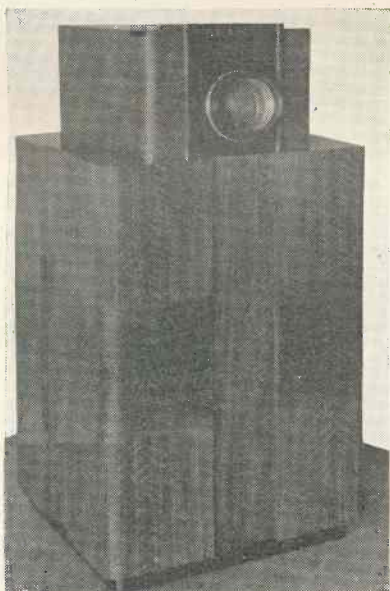

*Fernseh cathode-ray projector.*

were in my opinion representative of what can be done at present in cathode-ray technique.

The television exhibition was contained in a separate hall and according to reliable information the cost of equipping the building was in the region of half a million marks, excluding of course the apparatus itself.

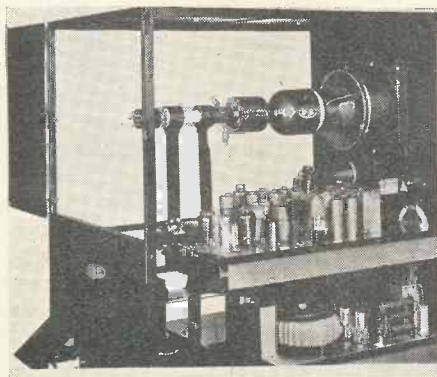

*Lorenz large screen projector.*

Three special theatres were built for three of the companies and demonstrations were given in each of these daily.

The main feature of the exhibition was the public demonstration of the long-awaited projected cathode-ray picture. This is the first time that the exhibition has demonstrated apparatus which on the receiving side was entirely electronic.

Four companies were demonstrating apparatus, as also were the Post Office, and a fifth, TeKaDe, although they had a stand in the television section, the exhibit consisted only of four non-working cathode-ray receivers in table size cabinets. In a glass case was a mirror screw, with associated cylindrical lenses, with a notice saying that this was the TeKaDe method of producing large television pictures. In the past, this company was noted for its low-definition pictures by mechanical methods.

The standard now adopted by the German companies is 441 lines, 50 pictures per second interlaced. All apparatus was demonstrated over line—no radio link at all was employed.

Of the number of systems demonstrated, that which in my opinion gave the best results was the Fernseh A.G. Two special demonstration theatres were in use. The most interesting of these contained two large screen high-definition projected cathode-ray pictures, the size of each being approximately 7 ft. by 6 ft. These were working side by side with a partition between them. Working on the 441 line standard, the results were extremely good except as regards brightness. These receivers were not working simultaneously. The cathode-ray images were projected on to a large ground glass screen.

Of the pictures reproduced, one was from an outside camera, which was viewing the public walking along the main promenade in the exhibition grounds. This was in operation nearly all day, and the camera was sometimes even left unattended. The detail was extremely good, it being possible to discern the rain during a very heavy storm and after the storm,

the wet ground offered an excellent test of the picture, as the reflections of people were clearly visible.

The picture was very evenly illuminated, and owing to this, a very steady picture and lack of flicker, the weak illumination was not noticeable after one had been in the theatre for a few minutes.

The best pictures seen on this apparatus were those received from the mechanical film transmitter. With these the definition was extremely good. I made observations on the life of the tube by going early in the morning and watching carefully for any burnt out screens during the day, and I found that on both these big screen receivers the tube tended to burn brown at the edges, an area about one-tenth of the picture. In a talk with an official of this Company he said that the life of these tubes was approximately ten hours and that they were changed daily. The screens used on these receivers were very transparent, but I did not notice any considerable light spot due to this. This apparatus was built to give large projected pictures regardless of cost.



*Interior view of Telefunken "Blok" Televisor.*

A total of 40 K.W. of controlled power was employed. The gun volts were in the region of 70,000 to 100,000, and that of the time bases 10,000 volts.

The apparatus controlling this was not on view, but it must have been of considerable cost and size, when one realises that the power used at Alexandra Palace is in the region of 17 K.W.

On the opposite side of the gang-way in the Fernseh section were two

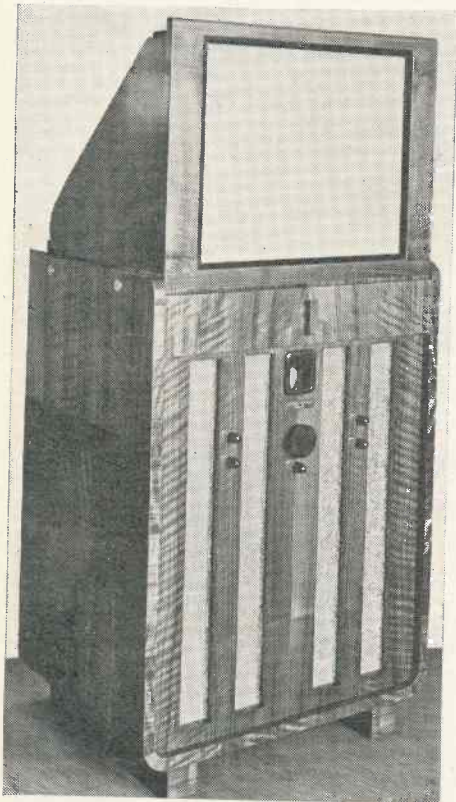

*Fernseh cathode-ray projection receiver.*

more projection cathode-ray receivers, one of which was in the form of a home receiver, self-contained in its cabinet. An 18-in. picture was projected on to a ground-glass screen. This was particularly poor from the point of view of light, gradation and definition. The colour of the picture was blue, and the total contrast ratio was, in my opinion, about 3:1. The poor definition I could not account for, but it was certainly no more than the equivalent of 100 lines, although it was reproducing pictures from the 441 line transmitting apparatus.

Behind this receiver in the other demonstration theatre was a cathode-ray tube projecting a picture on to a white screen. The size of this picture was approximately under 4 ft. x 3 ft., and the viewing distance was about

15 ft. The picture was very good, although the light was less than that of the larger pictures due no doubt to the front projection; there was also a certain amount of distortion round the edges of the picture, such as one would expect from a cathode-ray tube with a spherically shaped screen.

Pictorially the results were satisfactory, but here also I noticed that the screen turned brown and it was usually not working for long periods during the day.

The next largest picture shown by this Company was about 14 ins., viewed in a mirror in the usual way. (This was in a very large cabinet, too large for any ordinary room. The picture was the most impressive of any seen at the Exhibition, the lighting, gradation and black and white colours approaching cinema standards.

On the transmitting side the mechanical film transmitter used a Nipkow disc running in a vacuum as scanner for line scanning, and a second slotted disc scanner for interlacing with a filament lamp as light source. The photo-electric cell was an electron multiplier, giving a total gain of about one million. When this transmitter was in use, the received pictures, particularly the 14-in. picture, suffered from a very definite flicker at the bottom of the picture. (This was not always apparent, and was noticeable only on some of the films. This was explained as being due to film shrinkage affecting the interlacing.

The second transmitter in use utilised the Farnsworth image dissector tube. The pictures obtained with this were inferior to that of the mechanical apparatus.

Outside the Exhibition Hall on a specially built balcony two pick-up cameras were employed, one an Iconoscope and the other an intermediate film camera. The latter I did not see working at any time.

One of the special theatres was so constructed that the public could view the artists as they were being televised. The Iconoscope cameras were used here. The illumination was by incandescent lamps and the reproduction was, in my opinion, equal to that which we have seen from Alexandra Palace. (The demonstrations were more or less continuous throughout the day from one or other of the transmitting sources, and apart from the receivers mentioned above, a number of 12-ins. x 10-ins. pictures were shown simultaneously.

## Reichspost

Next to the Fernseh exhibit was that of the Reichspost, the German Post Office. They also had a special theatre complete with Iconoscope cameras, but the amount of illumination required appeared far in excess of that of the other companies. Apart from the usual incandescent lamps, mercury arc lamps were also used, and the light was so intense that the public was screened by a large coloured cellophane screen covering



*Telefunken 147-line cathode-ray scanner for public address.*

the entire proscenium opening. There was also a camera in the centre of the Exhibition grounds connected by a special cable, and dancers and singers were televised even during rain, a large umbrella being held over the apparatus.

The Reichspost film transmitter was, I understand, supplied by Fernseh A.G., and was the old type using an arc lamp with Nipkow disc scanner. The pictures from this were not as good as the Fernseh pictures and seemed to lack definition. (This was explained as being due to the intensity of the arc not remaining constant, so that the interlaced picture occasionally had black lines where the second picture ought to have been and giving a 25 pictures per second result.

*(Continued on page 544)*

# RECENT TELEVISION DEVELOPMENTS

## A RECORD OF PATENTS AND PROGRESS Specially Compiled for this Journal

Patentees :- Baird Television Ltd. and D. M. Johnstone :: Ferranti Ltd. and M. K. Taylor :: F. T. Farnsworth :: The General Electric Co. Ltd., H. W. B. Gardner and D. T. Russell :: Baird Television Ltd. and L. R. Merdler.

### Time-Base Circuits

(Patent No. 465,147.)

A TIME-BASE circuit for generating saw-toothed oscillations is arranged so that it can be used either for sequential scanning or for "interleaved" scanning.

As shown the valve V, which dis-

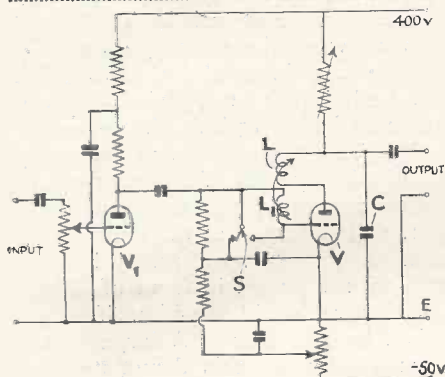

Time-base circuit for sequential or interlaced scanning. Patent No. 465,147.

charges the condenser C to produce the scanning oscillations, is back-coupled through the coils L, L1. In this condition it is self-operative, because it will discharge automatically as soon as the anode voltage reaches a certain potential, irrespective of whether or not a synchronising impulse is applied through the amplifier V1 to trigger it into action. The time-base is now suited for straight scanning.

By closing the switch S to short-circuit the grid coil L1, the oscillator valve V no longer discharges automatically, but only as and when impulsive by synchronising impulses received from the amplifier V1. In this condition it is adapted to reproduce interlaced pictures.—Baird Television, Ltd., and D. M. Johnstone.

### Television Receivers

(Patent No. 465,276.)

A super-regenerative amplifier used for receiving television is quenched, not only at a frequency higher than

that of the signals, but also at lower frequencies, corresponding (a) to the flyback period of each scanning line, and (b) to each successive frame, respectively.

The extra quenching impulses tend to counteract the effect of the original high-frequency interruptions, and so allow the amplifier to be worked at a highly-sensitive point without becoming unstable.—Baird Television, Ltd., and D. M. Johnstone.

### Coupling Circuits

(Patent No. 465,405.)

The figure shows a method of coupling a high-frequency amplifier in a television receiver to the detector stage. Between the ordinary tuned-anode circuit C, L and the anode of the H.F. valve V is inserted an additional coil K, which offers a high impedance to the whole range of frequencies to be handled by the rectifier. This prevents the input circuit to the detector D from being shunted, so far as signal frequencies are con-

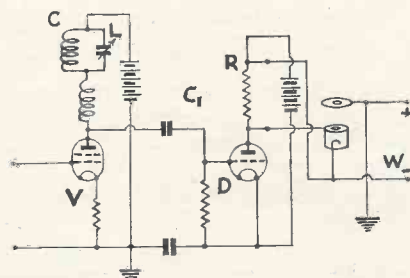

Method of coupling high-frequency amplifier to detector stage. Patent No. 465,405.

cerned, by the combined effect of the anode circuit C, L (which is tuned to the carrier frequency) and the coupling condenser C1.

The output from the detector is passed to the Wehnelt cylinder W of the cathode-ray tube. The load resistance R can be removed from the position shown, and inserted between the cathode of the detector D and the negative terminal of the high-tension supply. This allows a nega-

tive picture to be transformed into a positive one.—Ferranti, Ltd., and M. K. Taylor.

### Scanning Systems

(Patent No. 465,631.)

To secure fine detail a picture must be scanned through a small aperture, since the latter fixes both the number of lines to the frame and the size of each picture element. On the other hand, the use of a small scanning aperture severely limits the amount of light which reaches the photo-electric cell. This in turn reduces the contrast of the picture, that is, the overall distribution of high and low lights.

If a larger-sized aperture is used, the contrast values of the picture are preserved, though much of the detail is lost.

According to the invention, the picture is scanned, simultaneously, through a fine aperture and through a larger one. The two sets of signals are superposed at the receiving end, and so produce a picture which is satisfactory both in detail and in contrast values.—P. T. Farnsworth.

### Making Scanning Discs

(Patent No. 465,790.)

For high-definition work the holes in a scanning disc, about 0.002 in. in diameter, have to be accurately spaced along the periphery of a disc some 20 in. in diameter rotating at about 5,000 revs. per minute. It is impossible to punch such holes directly in a disc of sufficient strength, so that it is usual first to

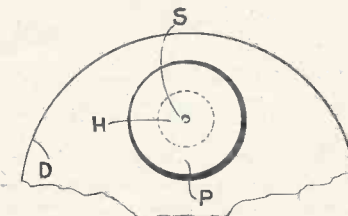

Method of making scanning discs. Patent No. 465,790.

The information and illustrations on this page are given with permission of the Controller of H.M. Stationery Office.

punch out relatively large holes and then to cover these with inserts of thinner material in which the very small apertures can be cleanly punched out.

As shown in the figure (which is not drawn to scale), the main scanning disc D is made of steel 0.008 in. thick. Comparatively large holes H about 0.1 in. in diameter, are first punched out and are then covered over by circular discs P made of platinum 0.005 in. thick and about 0.25 in. in diameter. The actual scanning aperture S is then punched out of this disc and is 0.002 in. in diameter. The "insert" disc P is spot-welded on to a very thin coating of copper and silver, which is first deposited on the surface of the disc D.—*The General Electric Co., Ltd., H. W. B. Gardiner and D. T. Russell.*

**Separating the Picture and Synchronising Signals**

(Patent No. 466,419.)

As shown in the drawing the incoming signals are applied at A to a double diode V in push-pull, and the resulting output is applied from the resistance R to the control grid of a

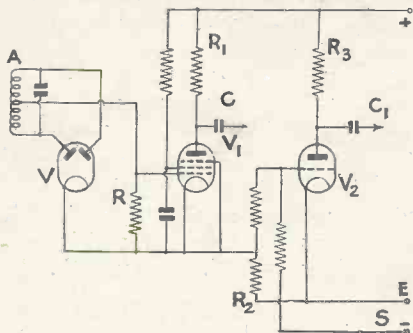

Separating synchronising and picture signals. Patent No. 466,419.

pentode valve V<sub>1</sub>. The picture signals appear across the anode resistance R<sub>1</sub>, and are applied through a condenser C directly to the control grid of the cathode-ray tube (not shown).

Simultaneously, the synchronising signals appear across a resistance R<sub>2</sub> in the cathode lead of the pentode V<sub>1</sub>, and are applied to the control grid of an auxiliary valve V<sub>2</sub>, which is negatively biased from a source S so that only peaks of current (corresponding to the synchronising impulses) can pass through the anode resistance R<sub>3</sub>. These are applied via the condenser C<sub>1</sub> to the scanning oscillator.—*Baird Television, Ltd., and L. R. Merdler.*

**Summary of Other Television Patents**

(Patent No. 465,953.)

Resistance-capacity-coupled push-pull amplifiers for handling a wide band of frequencies, e.g., television signals.—*British Thomson-Houston Co., Ltd., and R. G. Hibberd.*

(Patent No. 465,955.)

Time-base circuit in which a single discharge device produces two sets of scanning frequencies.—*Baird Television, Ltd., and E. E. Wright.*

(Patent No. 465,960.)

Photo-sensitive electrode for a cathode-ray tube television-transmitter.—*H. Miller.*

(Patent No. 465,141.)

Blocking out the "flyback" stroke in a synchronising system where a white margin surrounds the picture.—*Radio-Akt D. S. Loewe.*

(Patent No. 465,266.)

Cathode-ray tube in which the electron stream is produced by bombarding a target electrode.—*Ferranti, Ltd., and J. C. Wilson.*

(Patent No. 465,642.)

Mirror-drum scanner with means to prevent both curvature and divergence of the scanning lines.—*E. Traub.*

(Patent No. 465,715.)

Cathode-ray tube with checkerboard screen for still picture transmission.—*Telefunken Ges. für drahtlose Telegraphie m.b.H.*

(Patent No. 463,210.)

Controlling the electron stream in a cathode-ray tube of the cold-cathode type.—*W. Rogowski.*

(Patent No. 463,318.)

Television system in which a special band of frequencies is used to transmit slow variations in the background illumination of the picture.—*Hazeltine Corporation Inc.*

(Patent No. 464,831.)

Correcting the wedge-shaped distortion produced when scanning a picture by rotating discs fitted with spiral apertures.—*Radio-Akt. D. S. Loewe.*

(Patent No. 465,755.)

Method of converting a rectangular scanning-area into a trapezoidal one, particularly for transmitting pictures by means of an Iconoscope.—*Radio-Akt D. S. Loewe.*

**"German Television Progress"**

(Continued from page 542)

The Telefunken Company also had a full size stage and were using Iconoscope cameras. They also had an outside camera working, viewing the crowds in the grounds, and a number of home receivers in cabinets, giving pictures about 10 ins. with normal brightness. An interesting demonstration of apparatus was given at a low-definition standard, which could be more or less described as a "public address sound and vision system." In a separate theatre, the Telefunken Company had arranged a small cathode-ray tube which projected, via a large aperture reflecting mirror, an image of the raster on to the speaker. This was a form of cathode-ray flying spot projection, and only the head and shoulders were recorded. The colour was a very deep orange and the theatre was in semi-darkness. The reflected light was picked up by means of two 15 in. photo-electric cells. The picture was projected by a cathode-ray tube of a similar colour on to a ground glass screen about 5 ft. wide situated at the back of the theatre, and the speaker, by looking at a mirror placed in front of him in the theatre, could see himself reproduced by television. A large crowd always attended this demonstration.

According to Dr. Karolus, who developed this apparatus, the life of these cathode-ray tubes is more than 500 hours. The definition was 147 lines interlaced, 50 pictures per second.

I myself was televised by this apparatus, and was disappointed by the definition obtainable. I had with me the official hand-book, which has a large black figure on a light blue back-ground on its cover. This could not be clearly seen.

Two other companies also exhibited projected cathode-ray pictures. These were Loewe and Lorenz. All the pictures were about 5 ft. wide and working on the 441-line standard. The Loewe picture was very bad; it lacked definition, contrast and light and its apparent definition did not exceed 100 lines. This company also had an 18-in. picture, which was projecting on to a flat screen in the lid of a cabinet. The light here was so poor that it was some minutes before it was possible to see a picture at all after coming out of the sunlight. The Lorenz picture was also poor.

The information and illustration in the above two columns are given with permission of the Controller of M.M. Stationery Office.

# CONSIDERABLY IMPROVED SERVICE TO START AT ONCE

PLANS TO IMPROVE PROGRAMMES :: POSSIBILITY OF  
PROVINCIAL TELEVISION :: O.B.S :: INCREASED RANGE

THE past twelve months has been a probationary period for television and it has emerged from it with flying colours. A great deal of information has been obtained as to its possibilities and plans are now being made for a considerable extension of the service.

## Immense Possibilities

The most immediate of these are the alterations to Alexandra Palace which will result in better studio accommodation and this work is well forward. This, however, is not the most important feature which will influence the progress in the next twelve months. The B.B.C. has realised that the real future of television will depend on its ability to present viewers with pictures of events which are actually taking place and which can be presented by no other medium. The Coronation and Wimbledon broadcasts revealed the immense possibilities of this and although these transmissions were really experimental they proved that no public event taking place within reasonable distance from the Alexandra Palace need be considered as outside the scope of the possibilities of television.

Difficulties which previously it was thought might have a limiting effect, as for instance, artificial lighting, are being swept away. Cameras of greatly increased sensitivity have been produced and will be in use within the next month or so. This is a development which opens up possibilities of television under ordinary artificial lighting conditions, and there seems no reason why within the next few months it should not be possible to present excerpts from theatrical productions and many other indoor public functions.

Outside broadcasts already under consideration by the Alexandra Palace staff include the King's Cup Air Race in September, the Opening of Parliament, the Lord Mayor's Show and the Armistice Service. It

needs very little thought to perceive many other possibilities. There is, for example, the Boat Race, the Derby, football matches, prize fights, etc., and though the televising of some of these will depend upon the goodwill and collaboration of the

outlay. With increased service hours and programmes of a wider scope this objection will be swept away and the owner of a television receiver will be assured of getting value for money.

## More Money for Development

Financial considerations have proved a difficulty in the development of the service up to the present, but it is expected that the Postmaster-General will shortly announce in the House of Commons a grant of a considerable sum of money to the B.B.C. and it is reasonably certain that a large proportion of this will be allocated to television development.

Another important factor which will have a considerable bearing on the popularity of television as a means of home entertainment is the knowledge that has been obtained as the result of the experience of the past twelve months of the service range of the Alexandra Palace transmitter. Conditions vary in different locations, but consistently good pictures are being obtained up to distances of 70 miles. This is due in part to improved receiver design but it is well known that the original estimated service range was conservative.

The present exhibition will show that receiver design has become to a great extent standardised and this fact should do much to remove the impression that many people have that present-day television receivers are more or less experimental and likely to undergo extensive alteration which will quickly render them obsolete. In this connection, it should be remembered that the principles involved are by no means new and that they have been adapted for television purposes and not developed for it. The television receiver is excellent value for money compared with an ordinary broadcast set. Radio practice is employed and in the construction of receivers all the latest methods of radio component production are employed, facts which rule out the likelihood of any big price reductions.

## TRANSMISSION TIMES DURING RADIOLYMPIA

During Radiolympia, from August 25 to September 4, inclusive (Sundays excepted), there will be three hours' transmission daily as follows:—11.30 a.m. to 12.30 p.m., film; 4 p.m. to 5 p.m., actuality transmission; 9 p.m. to 10 p.m., actuality transmission.

After Radiolympia, from September 6 onward, normal programme hours (3 to 4 p.m., and 9 to 10 p.m.) will be given, with an extra morning hour for trade purposes as follows:—10.30 to 11 a.m., cruciform pattern with tone; 11 a.m. to 12 noon, demonstration of magazine film with sound.

authorities concerned there is no doubt but that there is a very big field of entertainment upon which the B.B.C. can draw.

## Provincial Television

The possibilities of television in the provinces are being investigated and although no decision has been reached, either as regards the erection of new stations or relays of the existing programmes by means of land line, there is little doubt but that this is a development which will come about in the near future.

The complaints of rather short hours of service have also been receiving attention and when the present alterations to the Alexandra Palace are made it is probable that the time of transmission will be increased by an hour at first with a possibility of further extension at an early date. Limitation of hours and the restricted types of programmes have in the past had an effect upon the sales of receivers, the opinion of the public being that insufficient return in the way of entertainment was likely to be had for the



**“RADIOLYMPIA—ITS PICTURES & RECEIVERS”** (Continued from page 538)

**THE MARCONIPHONE CO., LTD., 210, Tottenham Court Road, London, W.C.1. STAND Nos. 53 and 64**

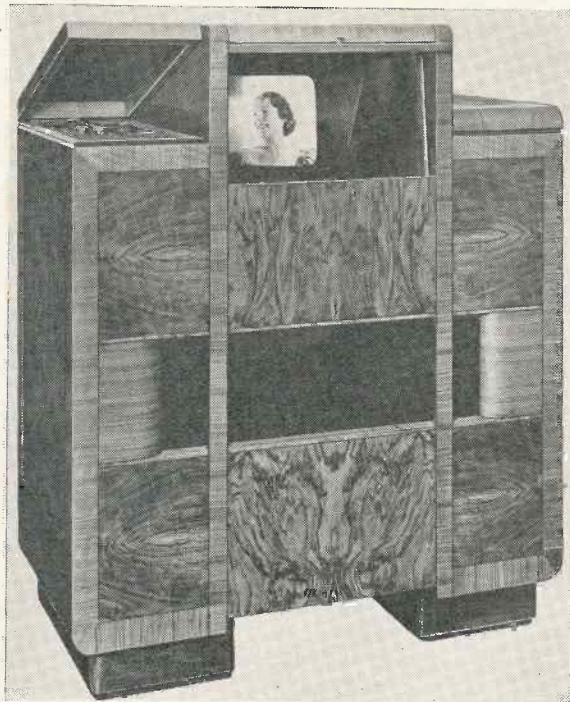

Marconiphone television and all-wave receiver.

The Marconiphone Model 703 Mastergram television receiver comprises a television receiver, a four-band radio receiver covering the following wavelength ranges:—16.7-53 metres, 46-140 metres, 185-560 metres, 750-2,200 metres, and an automatic record-changing gramophone.

The vision equipment comprises:—(a) The Emiscope Tube Unit and its associated fitting; (b) the Visi-Receiver Unit which consists of a 6-valve T.R.F. receiver, fixed-tuned to 45 megacycles (6.67 metres).

The size of the picture is 10 in. by 8 in., and it is viewed in a mirror supported in the cabinet lid.

The television controls are grouped around the top board which masks the end of the Emiscope cathode-ray tube. They are:—The Line Hold Control, the Frame Hold Control, the Brightness Control. (Mounted in this order from back to front to the left of the Emiscope cathode-ray tube mask.) The sensitivity Control (left), the Contrast Control (right). (These are positioned between the front edge of the Emiscope cathode-ray tube mask and the front of the cabinet.) In addition, a sub-control panel which is mounted on the left immediately behind the Line Hold Control carries four pre-set controls which are adjusted on installation, and once set should not need re-adjustment for a considerable period.

The Sound Receiver unit is a normal broadcast chassis adapted to deal with the television sound broadcasting on 41.5 megacycles (7.23 metres) as well as the normal long-wave, medium-wave, and two short-wave bands.

**MULLARD RADIO VALVE CO., LTD., 225, Tottenham Court Road, London, W.1. STAND Nos. 75 and 161**

On the Mullard stand is shown a very comprehensive range of cathode-ray tubes for oscillograph and television purposes. These range in size from 3 in. to 15 in., the series including 3, 4, 6, 10, 12 and 15 inches. The prices are as follows: £3 10s. od.,

£6 15s. od., £8 8s. od., £12 12s. od. up to 10 in. The prices of the 12-in. tubes are £12 12s. od. and £15 15s. od. according to type. Of particular interest is the 15-in. magnetically focused tube priced at £15 15s. od. with a black and white

screen. (The second anode voltage of this tube is 4,000-5,000 volts and the ampere turns for the focusing coil are 500. All the Mullard tubes have indirectly-heated cathodes operated at 4 volts 1 ampere. A complete range of valves is also shown.

**PHILIPS LAMPS, LTD., 45, Charing Cross Road, W.C.3. Stand No. 68.**

One of the most interesting exhibits will undoubtedly be the Philips' large-screen television receiver which is one of the first of its kind to embody a small projection type cathode-ray tube. Although this tube is little more than 2 in. in diameter as compared with the more conventional 12 or 15 in. tubes, a picture is obtained 20 in. by 16 in. and viewed on a flat collapsible screen.

Another feature of this projection

system is that there is scope for further enlargement, for even with the present Philips' receiver by using a separate screen the picture can be increased in size to no less than 3 ft. square.

Many readers will appreciate the fact that when out of action the Philips' television receiver looks like a conventional radio-gramophone and has fewer controls than usual.

Vision reception is practically automatic for the controls are pre-set and only need occasional readjustment. These controls are concealed, so giving the appearance of simplicity but

also guarding against accidental misadjustment.

The use of a small projection tube allows for a comparatively small cabinet and not one which is very wide from back to front. The Philips' instrument is housed in a cabinet 45 in. by 38 in. by 26 in.

**PYE RADIO, LTD., Africa House, Kingsway, London, W.C.3. Stand No. 60.**

The picture of the Pye Teleceiver is reflected in the mirrored lid, giving

(Continued on page 575)

# A T-20 Transmitter

*We publish this design of a 3 stage rack built transmitter in response to requests from those readers who have realised the possibilities of the new Taylor T20 valve.*

*Designed by  
Kenneth Jowers*

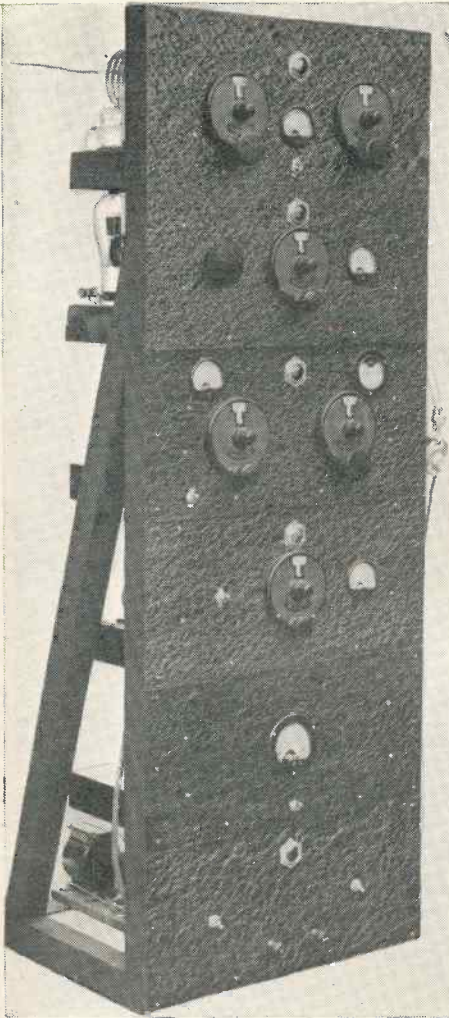

*Even though the transmitter has a really professional appearance the wooden rack used only costs 13/-.*

**W**HENEVER designing equipment of any kind for constructors I have endeavoured to use British components wherever possible in view of the fact that in many instances they are far superior to their foreign counterparts, while at the same time replacements are more easily obtainable.

However, during the last year or so it has become increasingly obvious that for medium power transmitting valves the American manufacturer was producing designs very suitable for the British amateur.

The superiority of American transmitting valves was most noticeable with those having a rating of 50 watts or more. British valve makers have been modifying the design of larger type receiving valves for the use of amateurs and these have been quite successful as oscillators, doublers and power amplifiers.

Earlier in the year, however, a new valve, the Taylor T20, was marketed in this country, and from early information seemed to be far in advance of any

other valve of a similar type and wattage.

By reducing the inter-electrode capacity, including a ceramic base and very low-loss construction, the radio-frequency output for a given input is greatly in advance of any other 25 watt valve. Also the excitation required is comparatively low, while a small valve of neutralising capacity could easily be obtained by using a wide gap two-plate condenser.

In construction the valve lends itself to amateur use and rack built transmitters for the anode is brought out to the top cap. This enables the grid circuit to be in one compartment with the anode circuit above it and completely screened. This type of construction means minor alterations in conventional design such as grid neutralising, but ultimately the results were considerably in advance of those obtained from similar transmitters with inefficient valves.

As previously mentioned the entire transmitter is built in a rack and with the exception of the mains lead and link-coupled aerial is entirely free of external wiring. Illustrations show just how simple is the construction and how neat an amateur transmitter can be made without going to unnecessary expense.

Do not retain the mistaken idea that the rack must be expensive, for the original one used in this transmitter

cost only 13s., being made up of 5s. 6d. for the necessary wood planed and cut, and 7s. 6d. carpenters' charges for assembly.

The rack has a total height of 51 in. with an overall width of 19 in.; and a base merely to form a steadying platform of 14 in. from back to front, and of course 19 in. wide. Two bracing pieces from the top of the rack to the back of the platform make it absolutely rigid and free from whip. Throughout 1/5-8ths in. square wood is used and as this is soft deal is easy to handle.

Now refer to the illustrations showing the complete transmitter. Notice that there are six distinct sections and the panels are standard radio relay size having a width of 19 in. In the bottom rack are two power packs one for feeding the crystal oscillator and the sub-amplifier with the second feeding the power amplifier.

The primaries of both transformers are independently switched, but the HT secondaries are taken to common terminals across which is bridged the switches S6 and S7. Actually S6 and S7 are connected to the transmitter by a long flexible wire so acting as a remote control.

On the left hand side of the bottom rack is the power pack giving 350 volts and 120 m/a. This output is smoothed by a high inductance choke and two 8-mfd. electrolytic condensers. An indirectly heated valve type UU3 is used

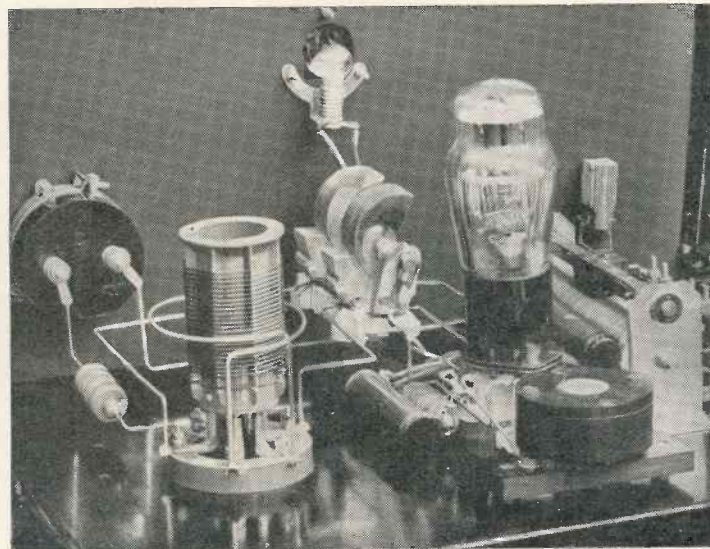

*Here is the push-pull crystal oscillator stage using a 53 twin triode. Notice the single turn link loosely coupled to the anode coil.*

# Progress in Television

## THE MULLARD CATHODE RAY TUBE Type M. 46-15



TYPE M. 46-15  
PRICE 15 GNS.

A selection from the range of Mullard Cathode Ray Tubes for Television and Oscillographic purposes

TYPE NO.	SCREEN COLOUR & APPROX. DIAMETER	MAX. ANODE VOLTS	DEFLECTION METHOD	LIST PRICE
M.46-15	White 15"	5,000	Electro-Magnetic	£15 15s.
M.46-12	White 12"	5,000	Electro-Magnetic	£12 12s.
EM.46-12	White 12"	5,000	Electro-Static	£15 15s.
E.46-12	White 12"	5,000	Electro-Magnetic	£15 15s.
E.46-G10	Green 10"	5,000	Double Electrostatic	£12 12s.
E.42-B6	Blue 6"	2,000	Double Electrostatic	£ 8 8s.
A.41-N4	Green* 4"	1,200	Double Electrostatic	£ 6 15s.
E.40-G3	Green 3"	800	Double Electrostatic	£ 3 10s.
4002	Green 4"	1,000	Double Electrostatic	£ 6 15s.

\* Special Long Persistence Screen.

Write for Technical  
Information Sheet,  
giving full data, to:—

# Mullard

Wireless Service Co. Ltd.,  
Cathode Ray Tube Dept.,  
225 Tottenham Court Road,  
London, W.1.

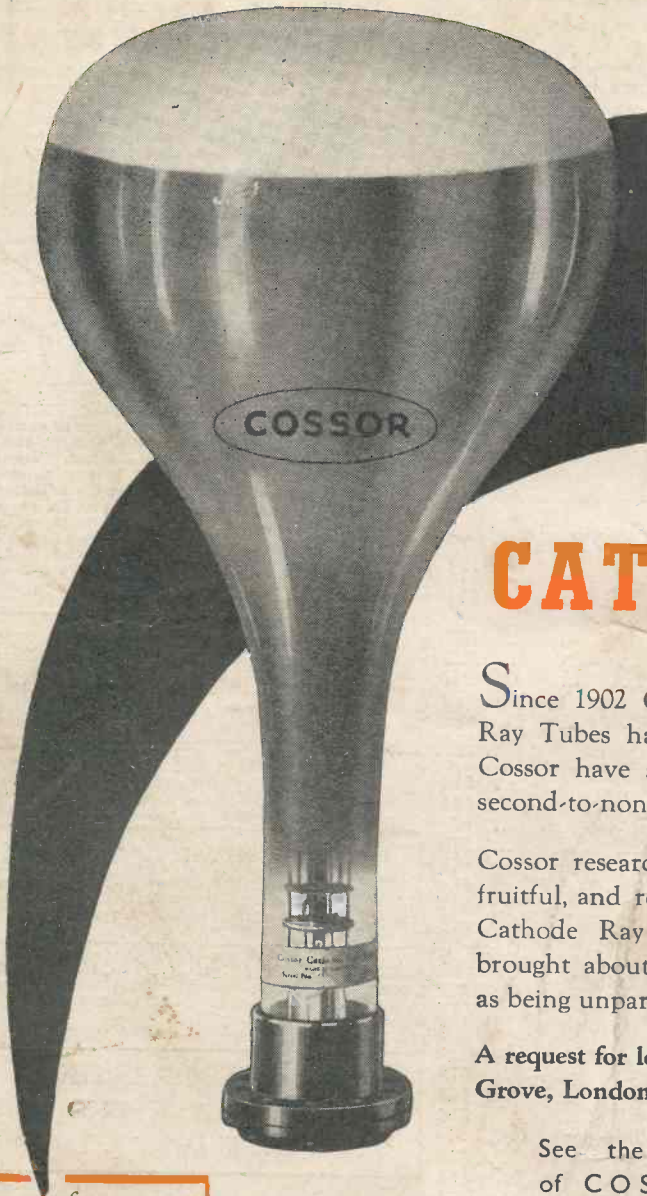

*from the most  
comprehensive range  
of*

## CATHODE RAY TUBES

Since 1902 Cossor research in the design and practice of Cathode Ray Tubes has always kept ahead of the times. As a result to-day Cossor have available a comprehensive range of Cathode Ray Tubes second-to-none.

Cossor research in the field of Television too, has proved eminently fruitful, and results have amply justified their pioneer work in the use of Cathode Ray Tubes for Television. Progress in this sphere has brought about many types but the Cossor full range of tubes is admitted as being unparalleled in respect of quality, focus and brilliance.

A request for leaflet L.213 to Instrument Dept., A. C. Cossor Ltd., Highbury Grove, London, N.5, will bring full details and data of the range available.

See the range of COSSOR CATHODE RAY TUBES ON	<b>STAND 163</b>	COSSOR TELEVISION RECEIVERS ON	<b>STAND 61</b>
---	----------------------	--------------------------------------	---------------------

*from the*  
**'WIRELESS WORLD'**  
Editorial 2.4.37.

"It was not until about thirty years later that the cathode-ray tube came to be regarded as an every day instrument in the laboratory, although as long ago as 1902 Cossors, the valve manufacturers, were producing their first examples."

# COSSOR

## CATHODE RAY TUBES

A. C. COSSOR LTD., Highbury Grove, London, N.5

2860